

# TECHNICAL INFORMATION



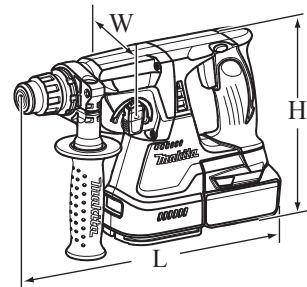
PRODUCT

P 1 / 25

**Models No.** ▶ BHR242 (LXRH01\*1), BHR243 (LXRH02\*1)

**Description** ▶ Cordless Combination Hammer 24mm (15/16")

\*1 Model number for North and Central American countries.



Dimensions: mm (")		
Length (L)	<b>BHR242</b>	328(12-7/8)
	<b>BHR243</b>	353(13-7/8)
Width (W)	85 (3-3/8)	
Height (H)	213 (8-3/8)	

## CONCEPT AND MAIN APPLICATIONS

The subject models are 24mm (15/16") Cordless Combination Hammers powered by 18V Li-ion Battery, featuring:

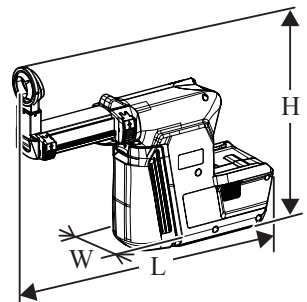
- Efficient Brushless DC motor provides higher productivity than that of 18V Cordless Combination Hammer model BHR202.
  - Able to drill in concrete as fast or faster than 24V Cordless Combination Hammer model BHR200.
  - 3 operation modes (rotation only/ rotation with hammering/ hammering only)
  - Quick change drill chuck for models BHR243 (LXRH02\*1) only
  - Makita's first Cordless Combination Hammers with Dust extraction system.
- Note:** • These products are not compatible with 1.3Ah battery BL1815.

### DX01, DX02

These are the accessories as Makita's first Dust extracting system exclusively for model BHR242 (LXRH01\*1), BHR243 (LXRH02\*1).

This system is designed to collect dust effectively with on-off operation of the tool's on-off trigger switch interlocked with this system.

- Note:** • This system can be applied for concrete drilling only and comes with Dust case, Filter and 5 pcs. of extra Sealing caps.
- The following parts are available optionally:  
Dust case set, Filter set, Plastic carrying case (can be stored with BHR242 or BHR243)



Dimensions: mm (")		
Length (L)	<b>DX01</b>	372(14-5/8)
	<b>DX02</b>	397(15-5/8)
Width (W)	88 (3-1/2)	
Height (H)	287 (11-1/4)	

Dust extraction system	For Model and its Chuck system	
DX01	BHR242 (LXRH01*1)	Normal chuck
DX02	BHR243 (LXRH02*1)	Quick change chuck

## Specification

Model		<b>BHR242 (LXRH01*1)</b>	<b>BHR243 (LXRH02*1)</b>
Battery	Voltage: V	18	
	Cell	Li-ion	
	Capacity: Ah	3.0	
	Energy capacity: W	54	
Charging time: min.		22 with DC18RC (DC18RA*2)	
Capacity: mm (")	Concrete	24 (15/16)	
	Steel	13 (1/2)	
	Wood	27 (1-1/16)	
No load speed: (min-1= rpm)		0 - 950	
Blows per min.: (bpm=min-1)		0 - 4,700	
Chuck capacity: mm (")		10 (3/8)	
Bit shank		Adapted for SDS-PLUS	
Quick change drill chuck		No	Yes
Operation mode		3 modes (Rotation only/ Rotation with Hammering/ Hammering only)	
Variable speed control by switch trigger		Yes	
Constant speed control		Yes	
Reverse switch		Yes	
Clutch (Torque limiter)		Yes	
Weight of Dust extracting system: kg (lbs)		1.3 (3.0) for DX01, 1.4 (3.0) for DX02	
Weight according to EPTA- Procedure 01/2003: kg (lbs)		3.3 (7.2)	3.4 (7.6)

\*2: for North and Central American countries only

## Standard equipment

- Side grip assembly ..... 1
- Depth gauge (Stopper pole) ..... 1
- Plastic carrying case ..... 1
- Quick change drill chuck set  
for BHR243 (LXRH02\*1) only ..... 1

**Note:** The standard equipment for the tool shown above may vary by country.

## Optional accessories

- SDS-PLUS bits, Taper shank T.C.T bits,
- Taper shank adapter, Cotter, Center bit,
- Core bit adapter, Drill chuck assembly,
- Chuck adapter, Drill chuck S13,
- Chuck key S13, Keyless drill chuck,
- Tool holder set, Dust cup 5 & 9,
- Dust cup set, Bull point, Cold chisel,
- Grooving chisel, Scaling chisel,
- Scraper assembly, Grease vessel 30g,
- Blow out bulb, Safety goggles,
- Bit grease, Plastic carrying case,
- Battery BL1830,
- Fast charger; DC18RA\*2, DC18RC,
- Charger; DC18SC, DC24SC,
- Automotive charger DC18SE,
- Dust extraction system (DX01, DX02)

## ► Repair

**CAUTION: Repair the machine in accordance with “Instruction manual” or “Safety instructions”.**

### [1] NECESSARY REPAIRING TOOLS

Code No.	Description	Use for
1R003	Retaining ring pliers ST-2N	removing Ring spring 19 from Tool holder complete/ Tool holder guide complete
1R004	Retaining ring pliers ST-2	removing Retaining ring 21 for BHR243 from Armature shaft
1R033	Bearing setting plate 10.2	assembling Ring 8
1R035	Bearing setting plate 15.2	assembling Cam shaft
1R045	Gear extractor (large)	removing / assembling Spiro lock washer 30
1R139	Drill chuck extractor	removing Spiral bevel gear 32
1R164	Ring spring setting tool A	assembling Oil seal 25 to Gear housing complete
1R170	T-type hex wrench 3-127	removing M4 hex socket head bolts
1R212	Tip for Retaining ring pliers	attachment of 1R003
1R228	1/4" hex shank bit for M4	removing M4 hex socket head bolts (if the bolt head damages.)
1R232	Pipe 30	assembling Oil seal 25 to Gear housing complete
1R252	Round bar for arbor 30-100	removing Oil seal 25 from Gear housing complete
1R258	V block	assembling Oil seal 25 to Gear housing complete
1R269	Bearing extractor	removing Ball bearing 626DDW
1R273	Ring spring 26 setting tool B	assembling Cup sleeve / Ball bearing 6806LLU to Gear housing complete
1R281	Round bar for arbor 7-50	removing Spiral bevel gear 32
1R356	Bearing plate 10mm for arbor press	removing Ball bearings from Rotor
1R369	Jig for Spiro lock washer for spring type models	removing / assembling Spiro lock washer 30
1R388	Ring spring extractor	removing Ring spring 28

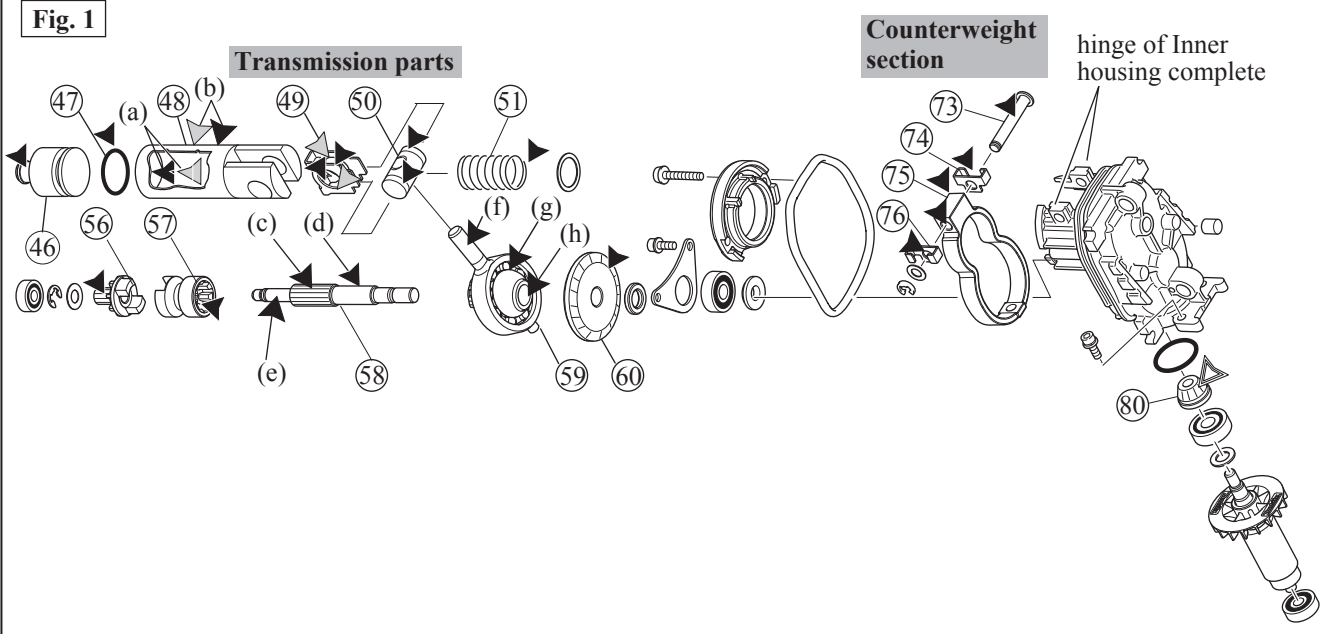
► **Repair**

**[2] LUBRICATION**

Apply the following grease to protect parts and product from unusual abrasion.

Item No.	Description	Portion to lubricate	Lubricant	Amount
(46)	Striker	Whole surface of projection	Makita grease RB No.00 ▼	a little
(47)	O ring 17.5	Whole surface		
(48)	Piston cylinder	(a) Inside where Striker moves (b) Outside that contacts Tool holder (guide) complete	Makita grease RB No.00 ▼ and Molybdenum disulfide ▼	a little
(49)	Guide plate	Inside that contacts (50) Piston joint		
(50)	Piston joint	Grooves that contact (49) Guide plate	Makita grease RB No.00 ▼	3g
(51)	Compression spring 14	End to be fixed to the boss in Inner housing complete (See Fig. 3.)		
(56)	Spur gear 10	Gear portion that engages with Spur gear 51		
(57)	Clutch cam A	Gear portion that engages with (58) Cam shaft		
(58)	Cam shaft	(c) Gear portion that engages with (57) Clutch cam A		
		(d) Portion to be inserted into (59) Swash bearing 10		
		(e) Cylindrical portion to be inserted into (56) Spur gear 10		
(59)	Swash bearing 10	(f) Pole portion to be inserted into (50) Piston joint		
		(g) Ball bearing portion		
		(h) Inside of hole		
(60)	Spiral bevel gear 32	Gear portion that engages with Armature shaft gear	See Fig. 3.	
(73)	Flat fillister HD pin 6	Portion that contacts the hinge of Inner housing complete		
(74)(76)	Weight holder guide			
(75)	Counter weight			
(80)	Spiral bevel gear 11 complete	Gear portion that engages with (60) Spiral bevel gear 32 [in the room of Inner housing complete for Spiral bevel gear 32]	Makita Grease FA No. 2 ▼	3g

**Fig. 1**

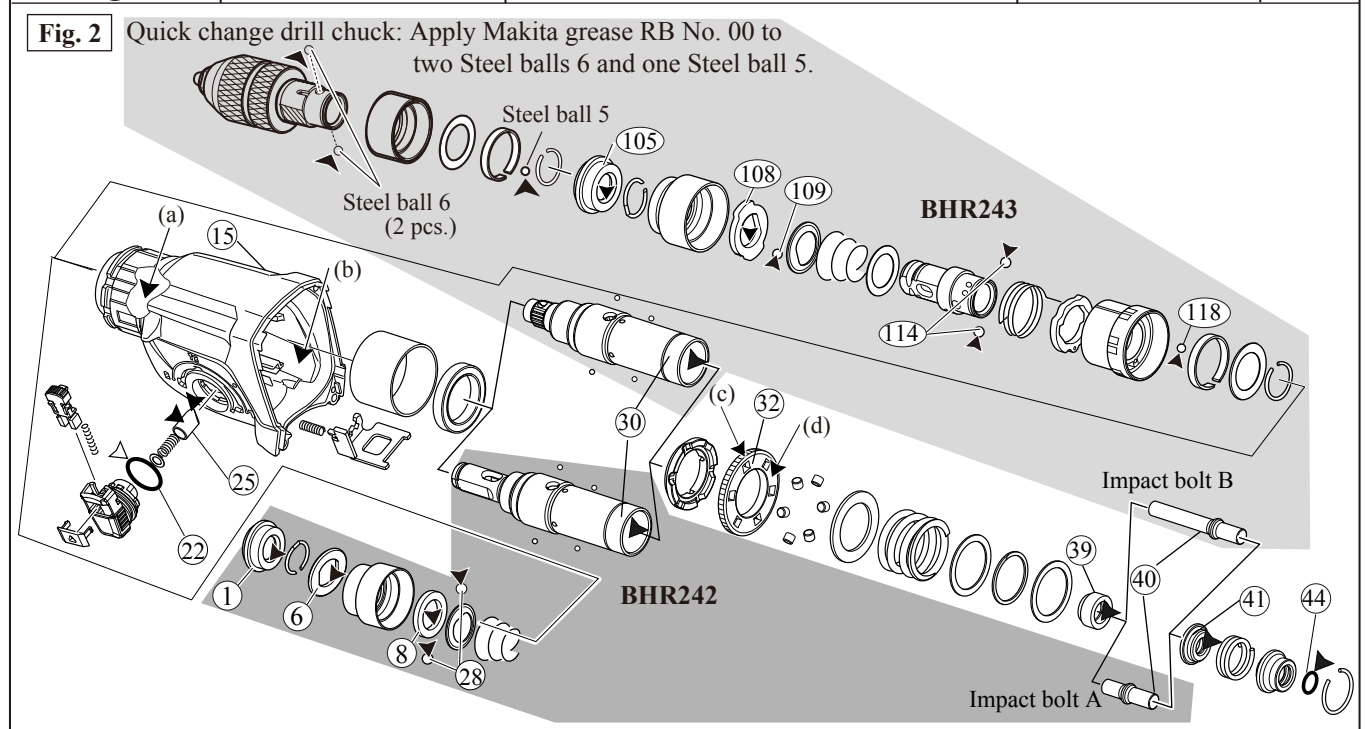


► **Repair**

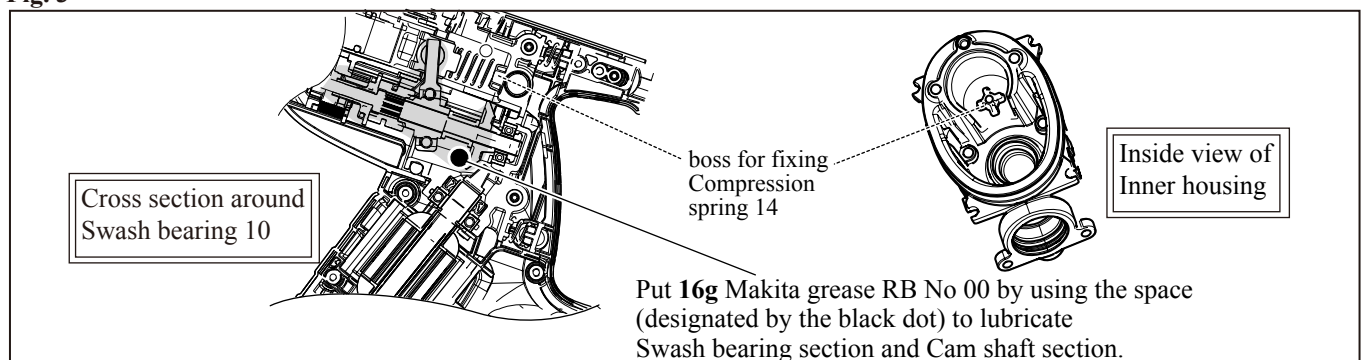
**[2] LUBRICATION (cont.)**

Apply the following grease/ oil to protect parts and product from unusual abrasion.

Item No.		Description	Portion to lubricate	Lubricant	Amount
BHR242	BHR243				
①	⑩⑤	Cap 35	Lip portion where Bit is to be inserted	Makita grease RB No.00 ▼	a little
⑥		Rubber washer 16	Inner periphery		
⑧		Ring 21	Inner periphery		
	⑩⑧	Stopper	Inner periphery		
	⑪④	Steel ball 6	Entire surface		
	⑪⑧	Steel ball 5.0	Entire surface		
⑮		Gear housing complete	(a) Oil seal 25 in Gear housing complete	Makita lubricating oil VG100 ▽	
⑳			(b) Inside where Swash bearing section rotates (See Fig. 3.)		
㉒		O ring 21	Entire surface	Makita grease RB No.00 ▼	2g
㉕		Push corn	Outer surface		
㉓		Spur gear 51	(c) Gear portion		
㉔			(d) Surface where Clutch portion of ㉓⑩ Tool holder (guide) complete contacts		
㉘	⑩⑨	Steel ball 7.0	Entire surface		
㉚		Tool holder complete	Inside where ㉘⑧ Piston cylinder reciprocates		
㉛	⑩⑩	Tool holderguide complete			
㉜		Sleeve 9B	Inside where Impact bolt A/ B reciprocates	Makita grease RB No.00 ▼	a little
㉞		Washer 10			
㉟		O ring 9			



**Fig. 3**



► **Repair**

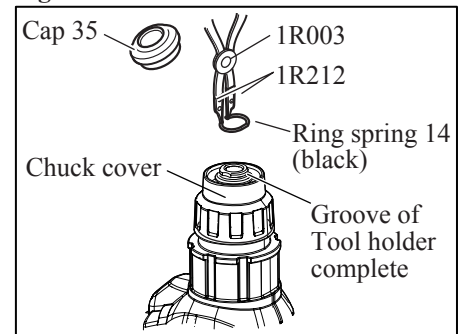
**[3] DISASSEMBLY/ASSEMBLY**

**[3] -1A. Bit holder section for BHR242**

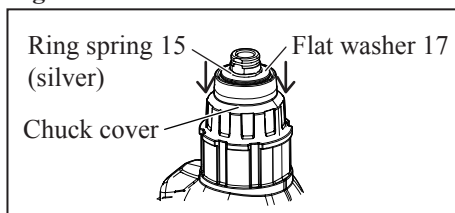
**DISASSEMBLING for BHR242**

- (1) Remove Cap 35.
- (2) Separate Ring spring 14 from the groove of Tool holder complete using 1R003 with 1R212. (Fig. 4)  
Washer 16 on Ring spring 15 is removed.
- (3) Remove Ring spring 15 in the same way while pressing down Chuck cover. (Fig. 5) Then pick up Flat washer 17 and Rubber washer 16 from the space between Chuck cover and Tool holder complete. Chuck cover is removed.
- (4) Remove two Steel balls 7.0 while pressing down Ring 21. (Fig. 6)  
Ring 21, Guide washer and Conical compression spring 21-29 are removed.

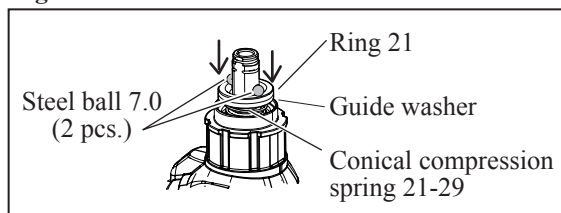
**Fig. 4**



**Fig. 5**



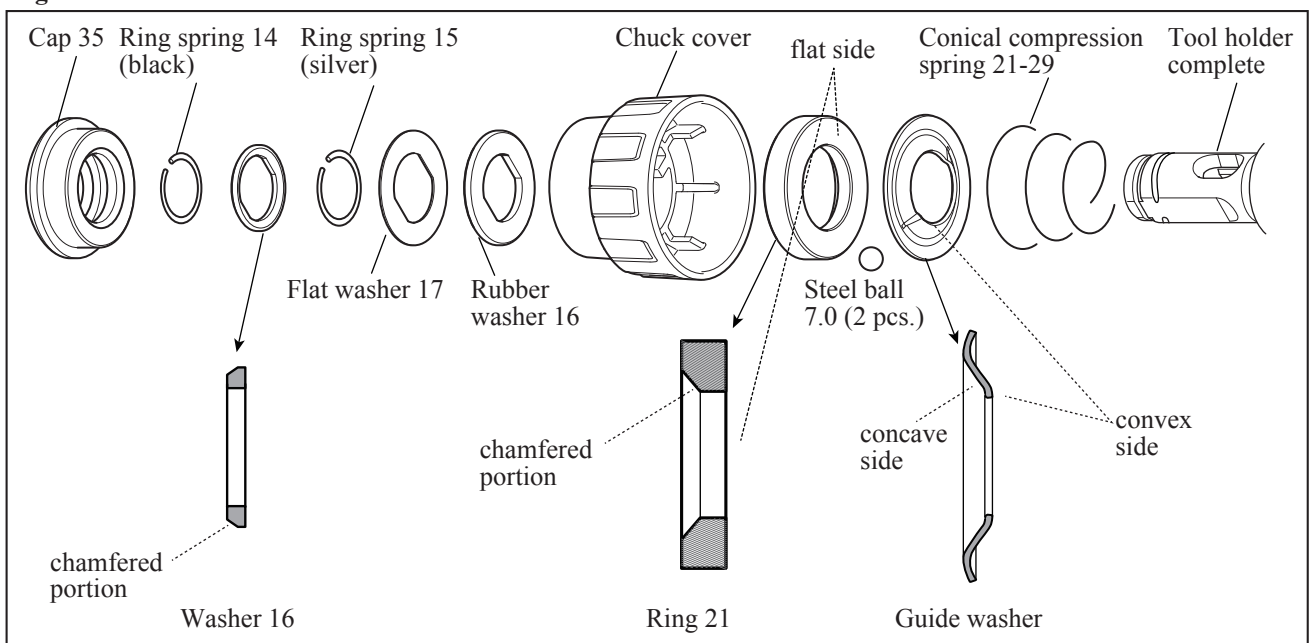
**Fig. 6**



**ASSEMBLING**

Assemble by reversing the disassembly procedure. Refer to Fig. 7 for the directions of the components.

**Fig. 7**



► **Repair**

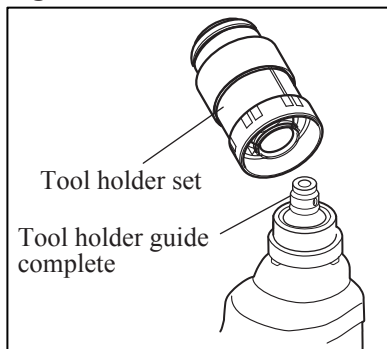
**[3] DISASSEMBLY/ASSEMBLY**

**[3] -1B. Holder section for BHR243**

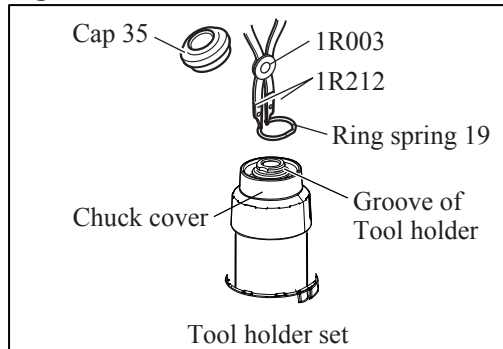
**DISASSEMBLING**

- (1) Remove Tool holder set from Tool holder guide complete. **(Fig. 8)**
- (2) Remove Cap 35, then separate Ring spring 19 from the groove of Tool holder using 1R003 with 1R212. **(Fig. 9)**
- (3) Remove Chuck cover, then remove Steel ball 7.0 while pressing down Stopper. **(Fig. 10)**  
Stopper, Guide washer, Conical compression spring 21-29 and Flat washer 21 are removed. **(Fig. 11)**
- (4) Remove Ring spring 21 with 1R004 from Tool holder guide complete side.  
Flat washer 24, Leaf spring and Steel ball 5 are removed. **(Fig. 12)**
- (5) Remove two Steel balls 6, Torsion spring 31 and Change ring from Tool holder. **(Fig. 13)**

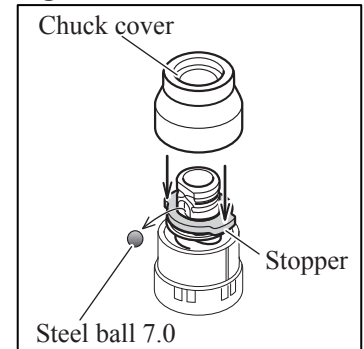
**Fig. 8**



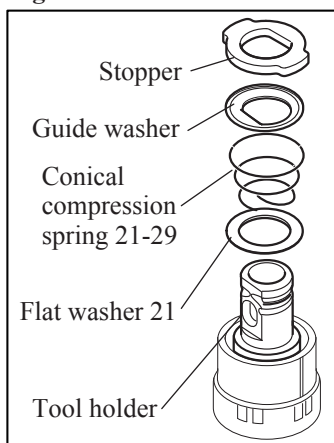
**Fig. 9**



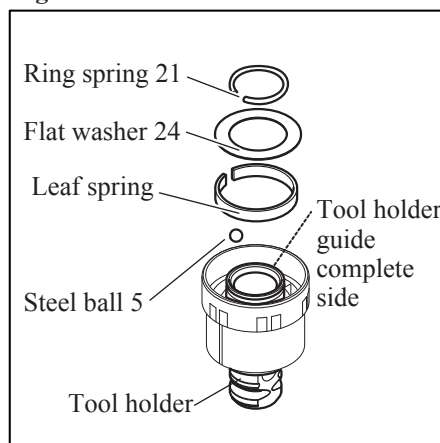
**Fig. 10**



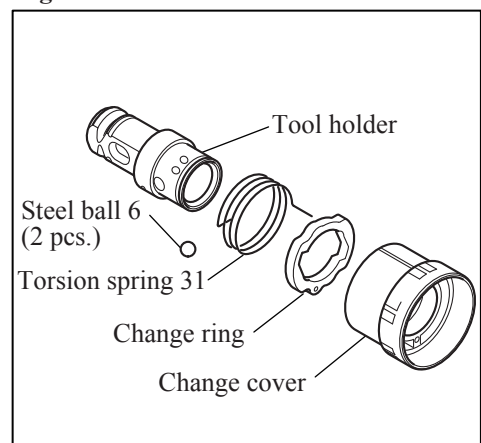
**Fig. 11**



**Fig. 12**



**Fig. 13**



## ► Repair

### [3] DISASSEMBLY/ASSEMBLY

#### [3]-1B. Holder section for BHR243 (cont.)

##### ASSEMBLING

- (1) Assemble Torsion spring 31 to Tool holder as follows:
  - Set two Steel balls 6 on the holes of Tool holder.
  - Insert the short arm of Torsion spring 31 into the hole of Tool holder.

**Note:** Apply Makita grease No. RB No. 00 to two Steel balls 6 to prevent them from falling. (Fig. 14)

- (2) Assemble Change ring to Change cover. (Fig. 15)
- (3) Assemble Tool holder to Change cover. (Fig. 16)

Fig. 14

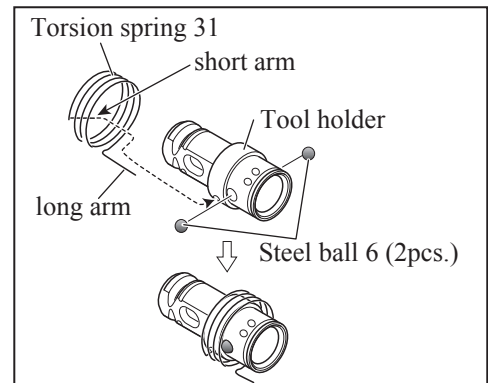


Fig. 15

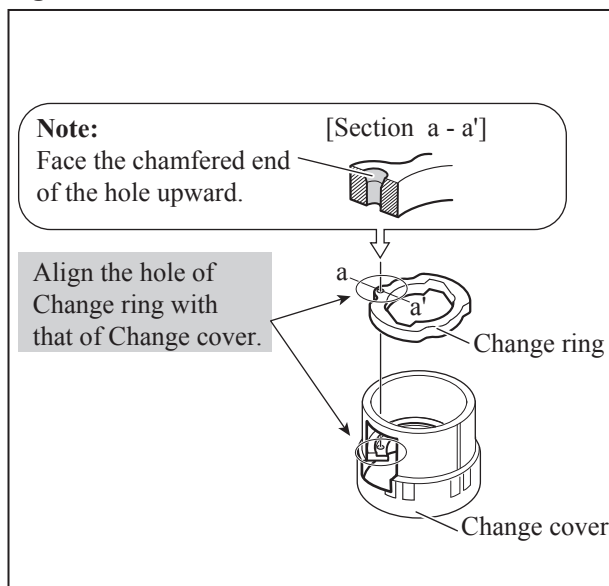
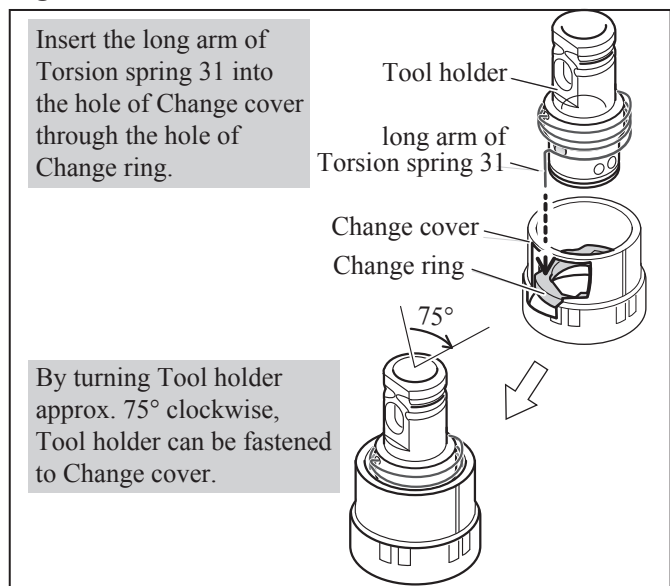
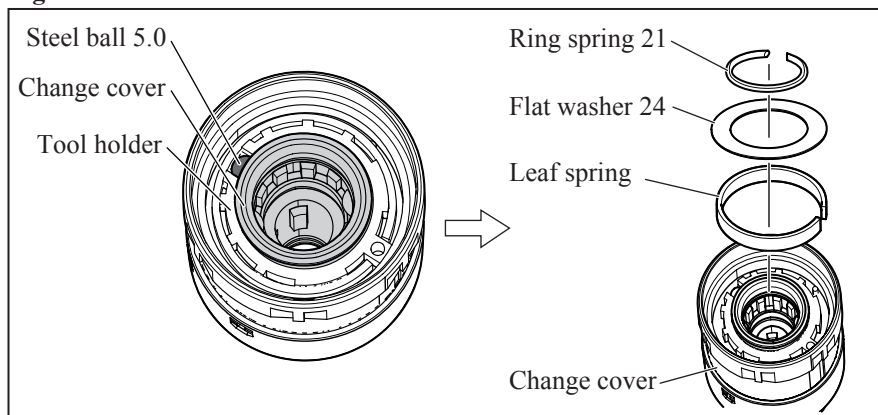


Fig. 16



- (4) Put Steel ball 5.0 in the groove surrounded by Change cover and Tool holder. (left in Fig. 17)
- (5) Set Leaf spring and Flat washer 24 in change cover, then secure them with Ring spring 21. (right in Fig. 17)
- (6) As for Cap 35 side, assemble the components by reversing disassembly procedure. Refer to the previous page.

Fig. 17



► **Repair**

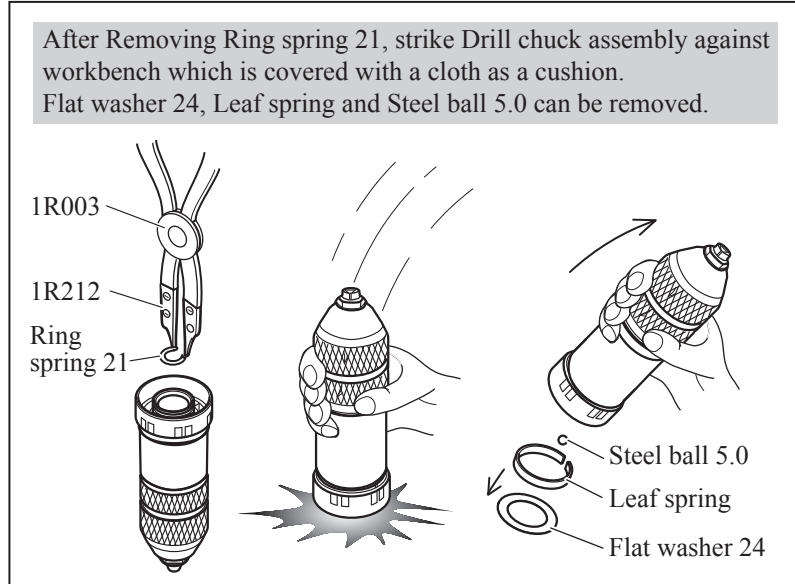
**[3] DISASSEMBLY/ASSEMBLY**

**[3]-2. Drill chuck assembly for BHR243**

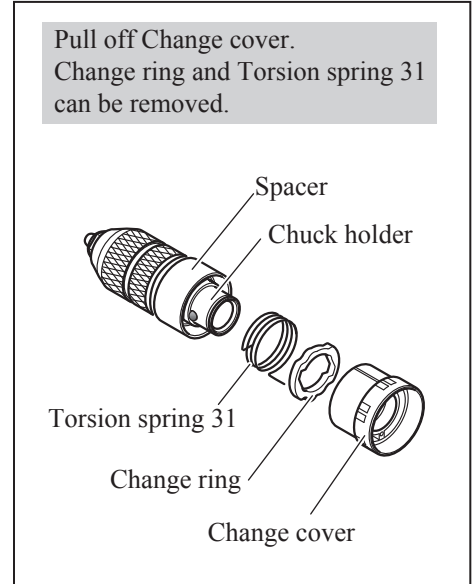
**DISASSEMBLING**

Drill chuck assembly can be disassembled as drawn in **Figs. 18 to 22**.

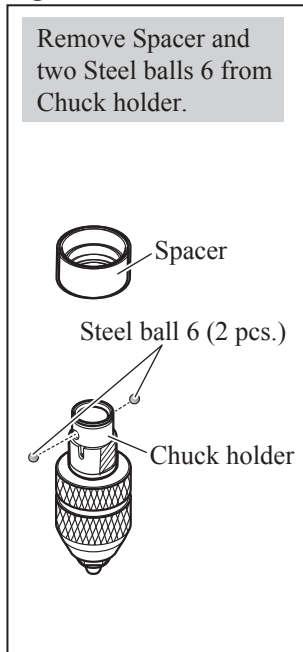
**Fig. 18**



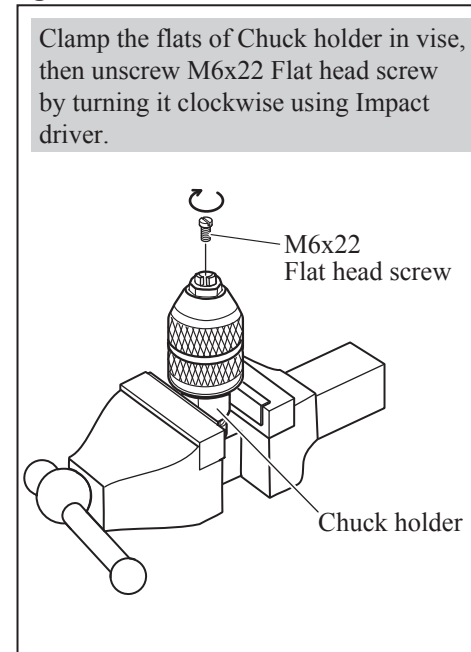
**Fig. 19**



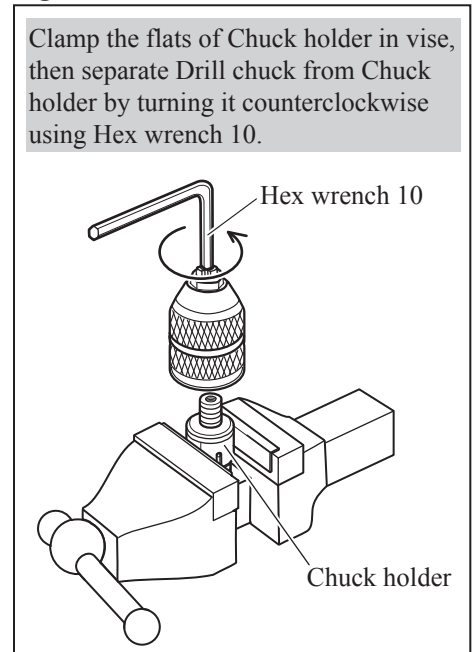
**Fig. 20**



**Fig. 21**



**Fig. 22**





► **Repair**

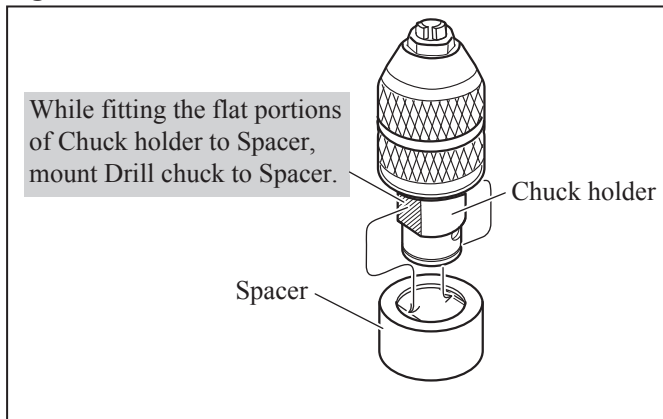
**[3] DISASSEMBLY/ ASSEMBLY**

**[3] -2. Drill chuck assembly for BHR243 (cont.)**

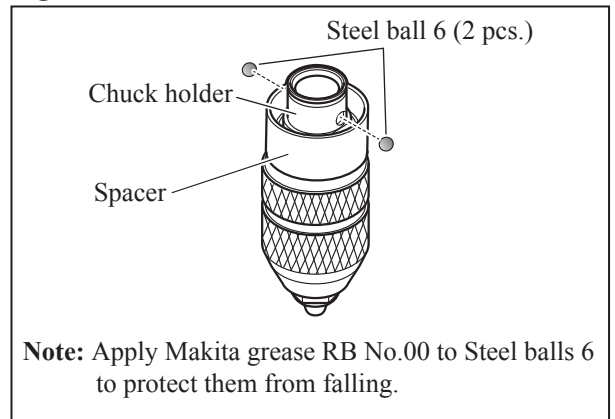
**ASSEMBLING**

- (1) Holding the flat portions of Chuck holder in vise, assemble Drill chuck to Chuck holder by turning it **clockwise** using Hex wrench 10.
- (2) Secure Drill chuck with M6x22 Flat head screw by turning it **counterclockwise** using Impact driver.
- (3) Assemble Drill chuck to Spacer. (**Fig. 23**) Then mount two Steel balls 6. (**Fig. 24**)
- (4) Mount Torsion spring 31. Then assemble Drill chuck to Change cover. (**Fig. 25**)
- (5) Mount Steel ball 5, Leaf spring and Flat washer 24 to Chuck holder, then secure them with Ring spring 21. (**Fig. 26**)

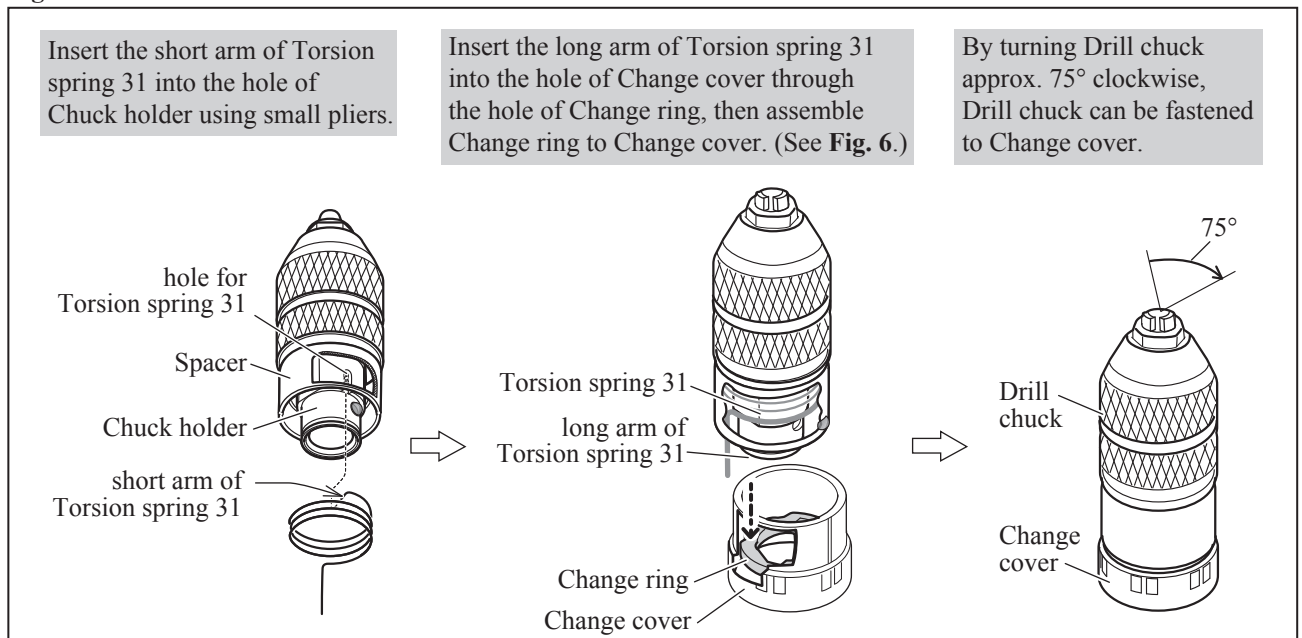
**Fig. 23**



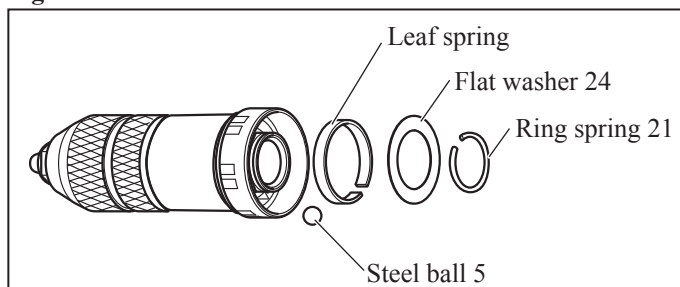
**Fig. 24**



**Fig. 25**



**Fig. 26**



## ► Repair

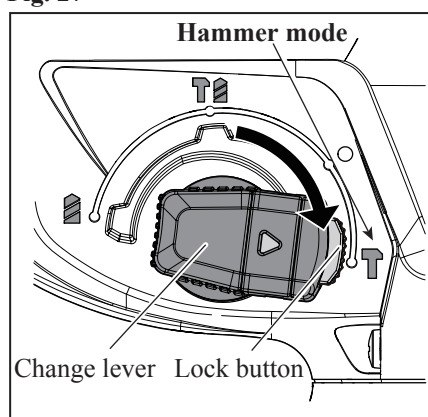
### [3] DISASSEMBLY/ASSEMBLY

#### [3]-3. Change lever

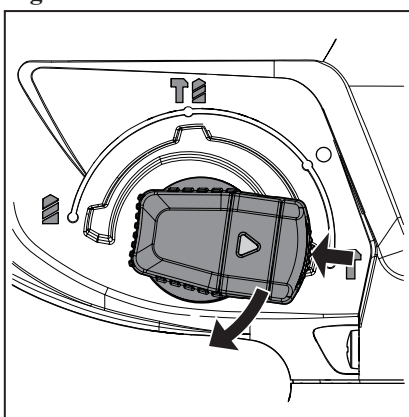
##### DISASSEMBLING

- (1) Remove dust and dirt from Change lever and the grooved area on Motor housing.
- (2) Set Change lever to Hammer mode. (**Fig. 27**)
  - Note:** If it is hard to set Change lever to Hammer mode because of getting stuck in the halfway, turn the bit holder section / holder section of the machine by hand and then try again.
- (3) While pushing Lock button into Change lever, turn Change lever to the right fully over the position of Hammer mode. (**Fig. 28**)
- (4) Pull out Change lever from the position drawn in **Fig. 29**. If it is impossible to remove Change lever by hand, lever it up with slotted screwdriver.
  - Note:** Be careful not to remove Change lever without placing as drawn in **Fig. 29**. The exact positioning prevents Change lever from breakage.
- (5) Disassemble Change lever section as drawn in **Fig. 2**.

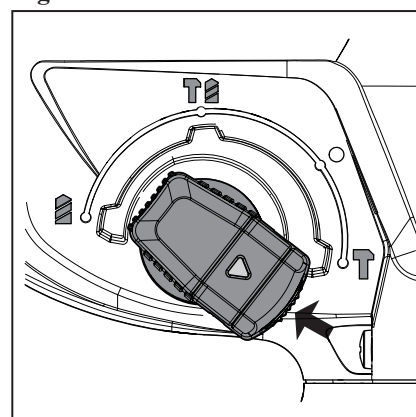
**Fig. 27**



**Fig. 28**



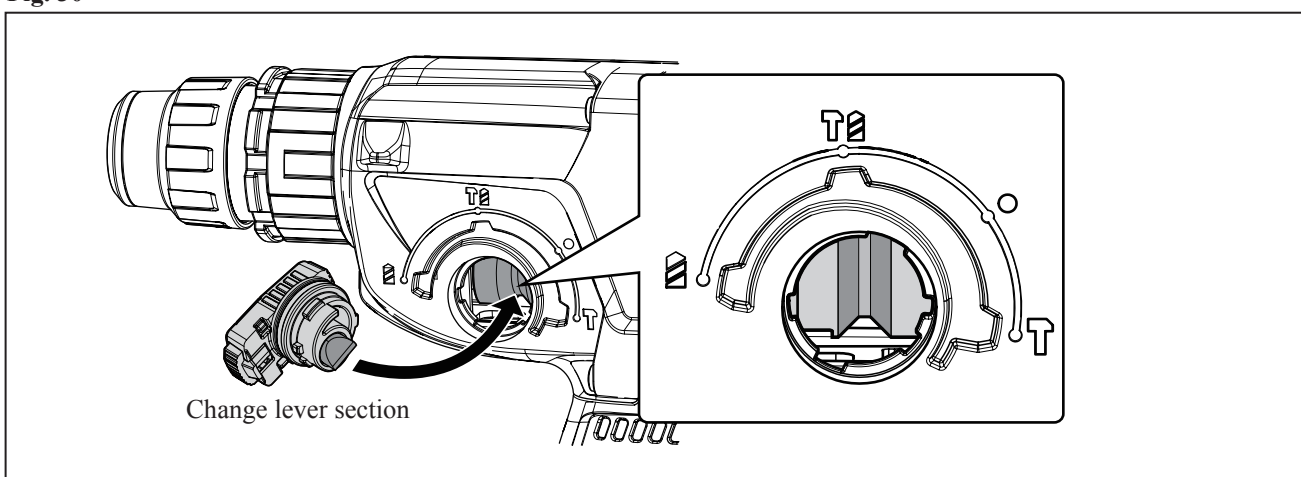
**Fig. 29**



##### ASSEMBLING

- (1) Assemble the following parts to Change lever.
  - Lock button ▪ Compression spring 3 ▪ Change lever cover ▪ O ring 21 (Apply Makita lubricating oil VG100.)
  - Thin washer 16 ▪ Compression spring 5 ▪ Push corn
- (2) Apply Makita grease RB No. 00 to Push corn.
- (3) Fit the top of Push corn into the groove of Clutch cam A, and insert the hinge of Change lever into the hole of Motor housing while keeping the exact position drawn in **Fig. 29**. (Refer to **Fig. 30**.)
- (4) While pushing Lock button, turn Change lever to the left.
  - Note:** Make sure that Change lever works properly by setting it to Drill mode/ Rotary hammer mode/ Hammer mode. If it is hard to set Change lever to each mode because of getting stuck in the halfway; try 1 or 2 as follows:
    1. Turn the bit holder section / holder section of the machine by hand and then try again.
    2. Install battery and pull Switch very slightly a second to run the machine.

**Fig. 30**



## ► Repair

### [3] DISASSEMBLY/ASSEMBLY

#### [3]-4. Rotor

##### DISASSEMBLING

- (1) Loosen four 4x35 Tapping screws, and then remove Battery housing R and Housing R in order from their housings L. (Fig. 31)
- (2) Remove Gear housing section as drawn in Fig. 32.  
Inner housing in Gear housing section comes with Rotor.
- (3) Loosen two M4x12 Hex socket head bolts with 1R170, and then remove Bearing retainer A. (Fig. 33)
- (4) Pull Rotor section out straight from Inner housing by hand.  
**Note:** Due to the effect of O ring 22.4 in the groove in Bearing room, pulling is preferable to tapping for removing Rotor section.
- (5) Insert a set of 1R356 under Ball bearing 608LLU, and press the shaft of Rotor in the center of Spiral bevel gear 11 complete with 1R281. (Fig. 34)  
Ball bearing 608LLU, Flat washer 8 and Spiral bevel gear 11 complete are removed.  
Remove 626DDW from Rotor with 1R269.

Fig. 31

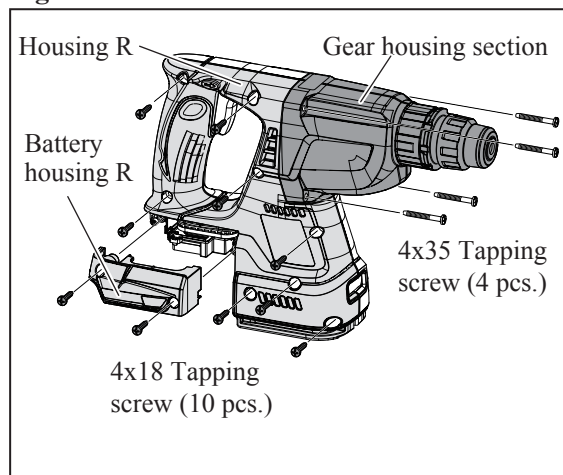


Fig. 32

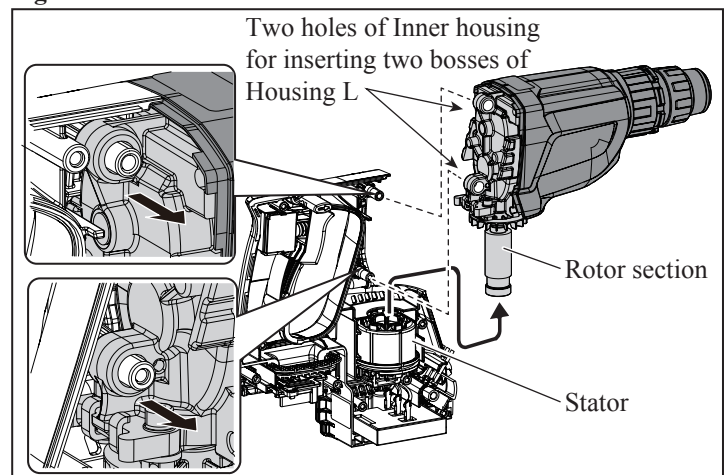


Fig. 33

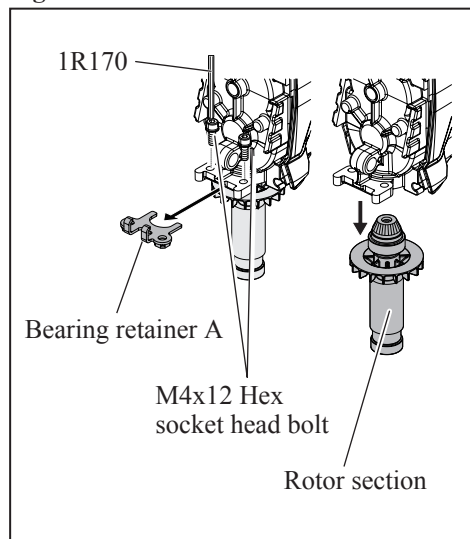
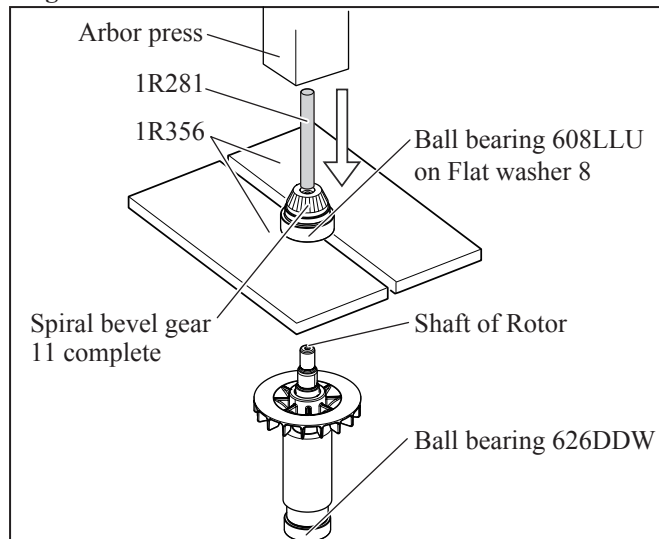


Fig. 34



##### ASSEMBLING

Assemble by reversing the disassembly procedure.

**Note:** Be sure to set Flat washer 8 in place between Fan and Ball bearing 608LLU.

► **Repair**

**[3] DISASSEMBLY/ASSEMBLY**

**[3]-5. Torsion spring 6 for Connector, Battery housing**

ASSEMBLING

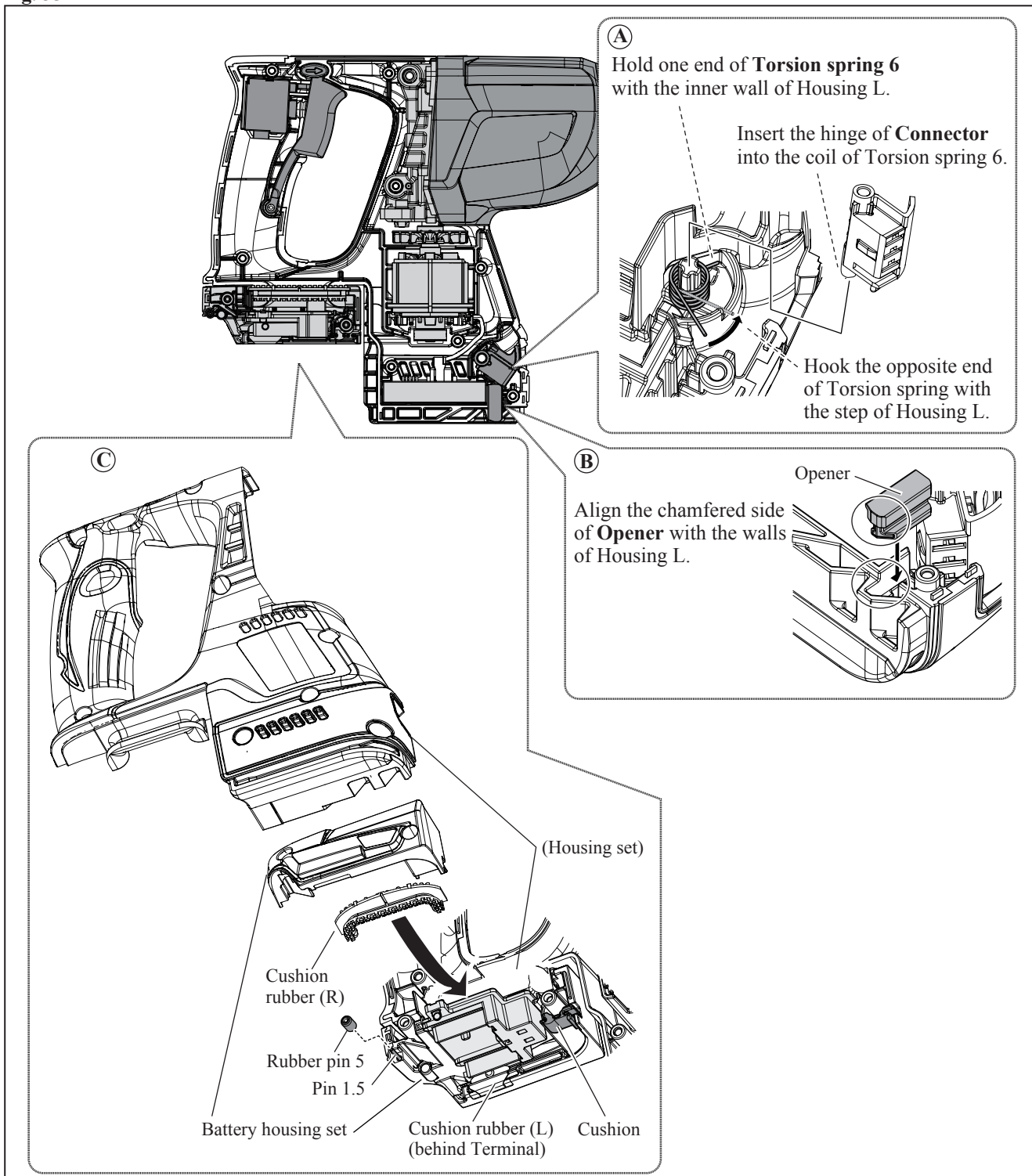
See **Fig. 35**.

Set Torsion spring 6 into Housing L, and then assemble Connector to Compression spring 6. Refer to (A).

Set Opener in place. Refer to (B).

When Battery housing L and R are matched, do not fail to assemble the parts shown in (C).

**Fig. 35**



► **Repair**

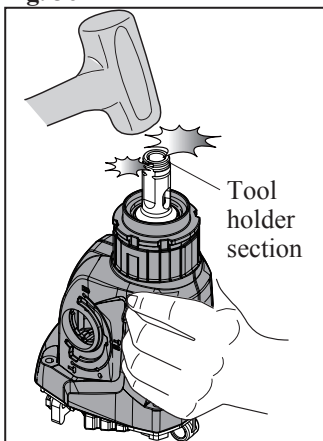
**[3] DISASSEMBLY/ASSEMBLY**

**[3]-6. Torque limiter section**

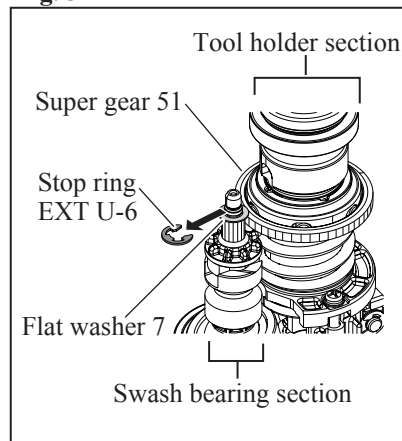
**DISASSEMBLING**

- (1) Disassemble Tool holder section. (Figs. 4 to 6 for BHR242/ Figs. 8 to 13 for BHR243.)
- (2) Disassemble Change lever. (Figs. 27 to 29)
- (3) Remove Gear housing section from Motor housing, and then remove Rotor section from Gear housing section. (Figs. 31 to 33)
- (4) While holding Gear housing section by hand, tap the top of Tool holder (guide) complete with plastic hammer. (Fig. 36)  
**Note:** 1. Grease falls from Gear housing section. Receive the grease with cloths.  
 2. Do not lose Flat washer 30 between Tool holder section and Inner housing.
- (5) Remove Stop ring EXT U-6 from Cam shaft. (Fig. 37)  
 The ring tends to be caught by Spur gear 51, and therefore, it interferes in the disassembling step.
- (6) Remove Tool holder section. (Fig. 37)
- (7) Set 1R045 and 1R369 to Tool holder section. (Fig. 38)
- (8) Compress Compression spring 31 of Tool holder section by turning the handle of 1R045 clockwise. (Fig. 39)
- (9) Remove Spiro lock washer 30 from Tool holder (guide) complete by gradually sliding it on Tool holder (guide) complete with Thin-slotted screwdriver. (Fig. 40) Tool holder (guide) section are disassembled as drawn in Fig. 41.

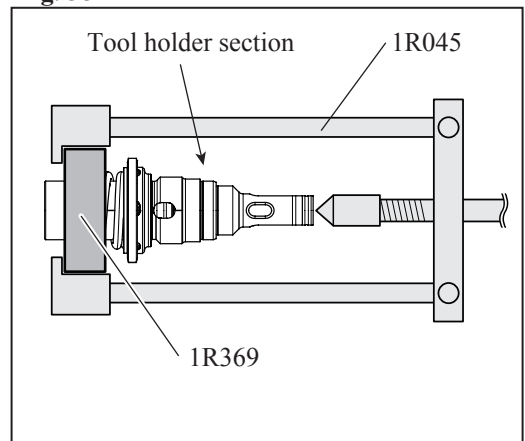
**Fig. 36**



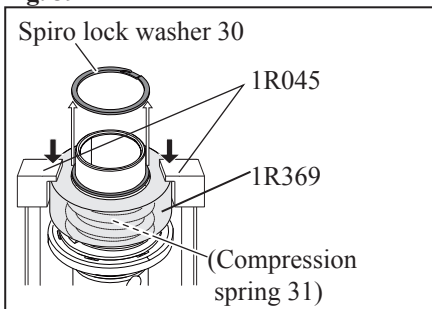
**Fig. 37**



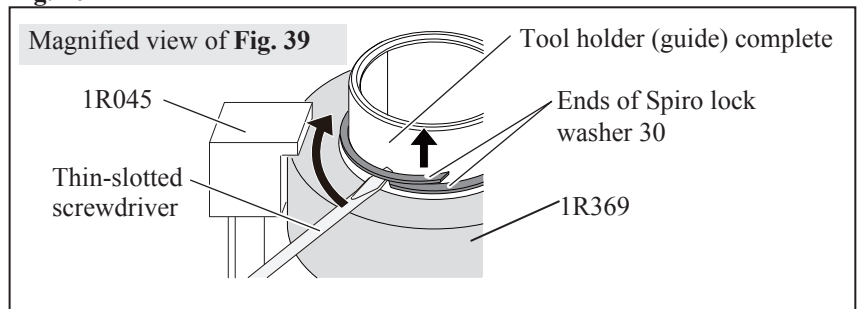
**Fig. 38**



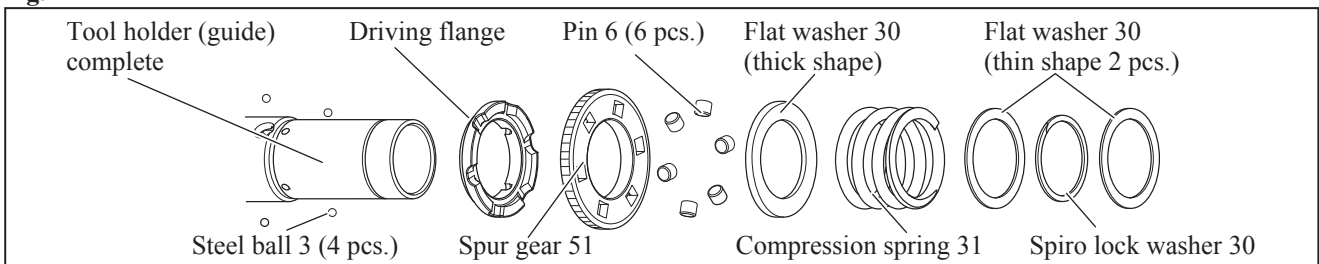
**Fig. 39**



**Fig. 40**



**Fig. 41**



**ASSEMBLING**

Assemble by reversing the disassembly procedure.

**Note:** 1. Set Spiro lock washer 30 in place with 1R369 and 1R045.

2. After assembling the components of Tool holder section, set Flat washer 7 and Stop ring EXT U-6 to Cam shaft. (Refer to Fig. 37)

► **Repair**

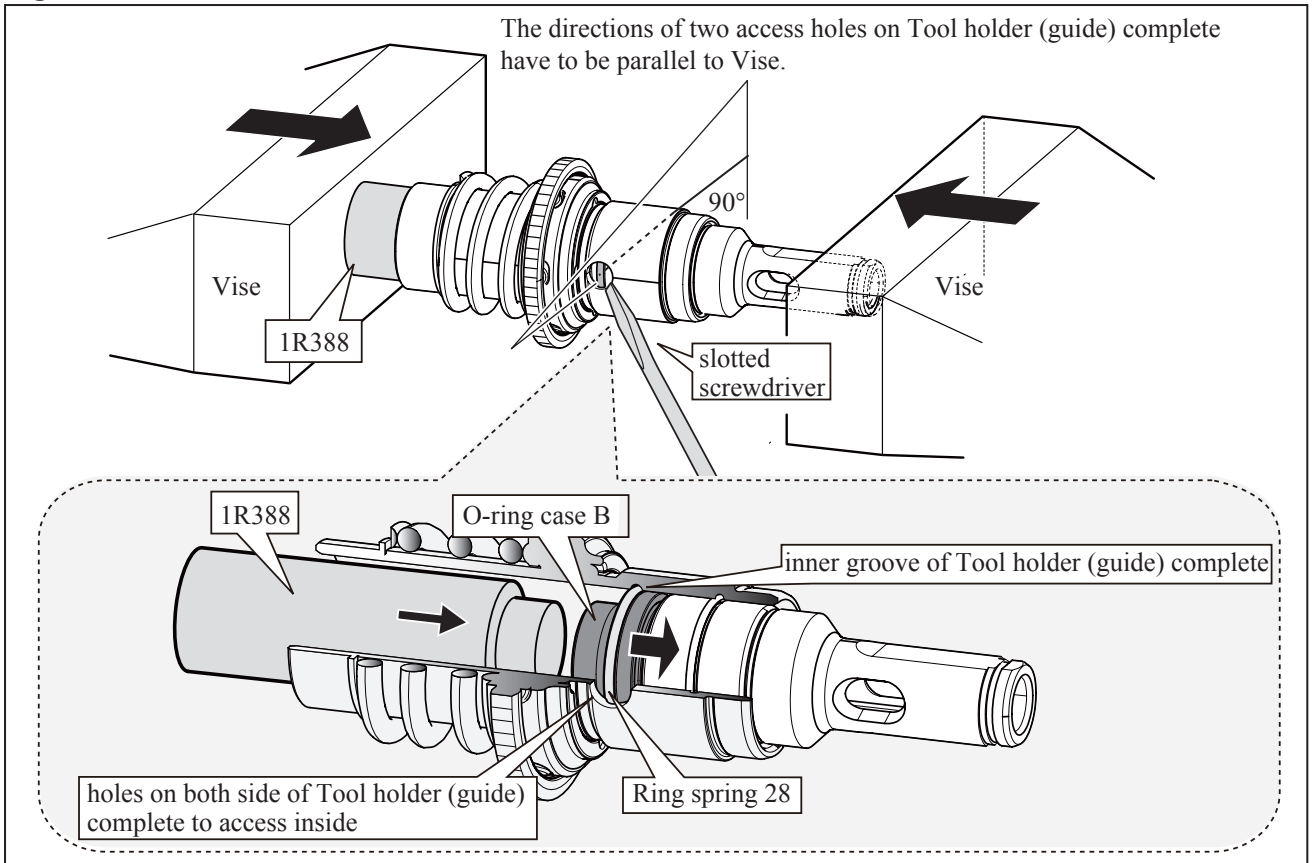
**[3] DISASSEMBLY/ASSEMBLY**

**[3]-6. Impact bolt in Torque limiter section**

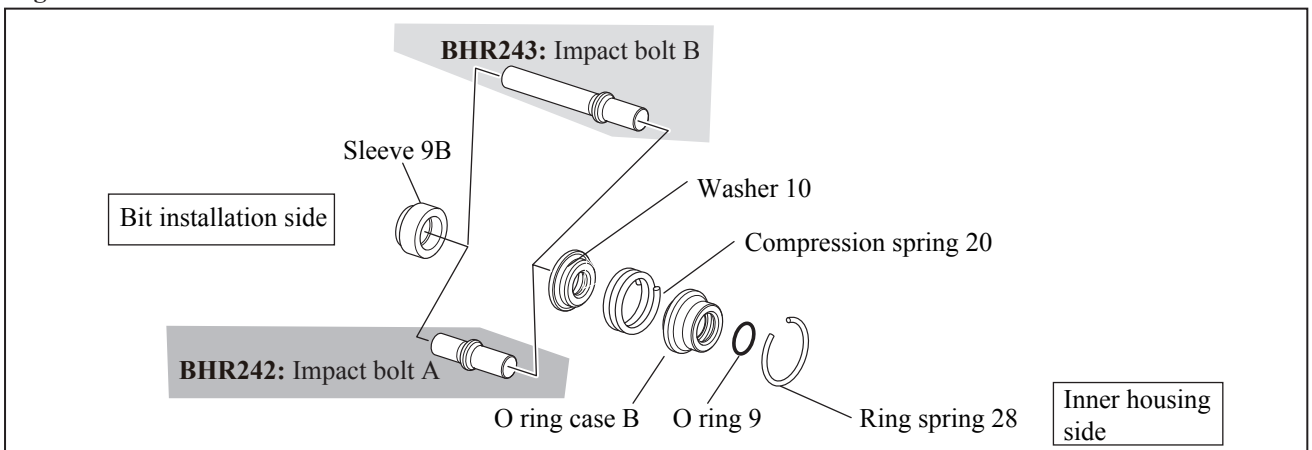
**DISASSEMBLING**

- (1) Put 1R388 into Tool holder (guide) complete, then push 1R388 in vise with the access holes on Tool holder (guide) complete parallel to Vise. (**Fig. 42**)  
 O-ring case B is moved toward the top of Tool holder (guide) complete, and therefore, Ring spring 28 can be relieved from O-ring case B.
  - (2) When the end gap of Ring spring 28 is in the access hole, slide it with slotted screwdriver until it is completely hidden.
  - (3) Using slotted screwdriver, tap Ring spring 28 through the two access holes alternately to push it out of the inner groove of Tool holder (guide) complete.
- Note:** As soon as a part of Ring spring 28 is removed from the inner groove of Tool holder (guide) complete, insert another slotted screwdriver in between Ring spring 28 and the inner groove of Tool holder (guide) complete to prevent returning the removed portion back to the inner groove.
- (4) The components are removed by tapping with Phillips screwdriver and Plastic hammer from bit installation side of Tool holder (guide) complete. (**Fig. 43**)

**Fig. 42**



**Fig. 43**



► **Repair**

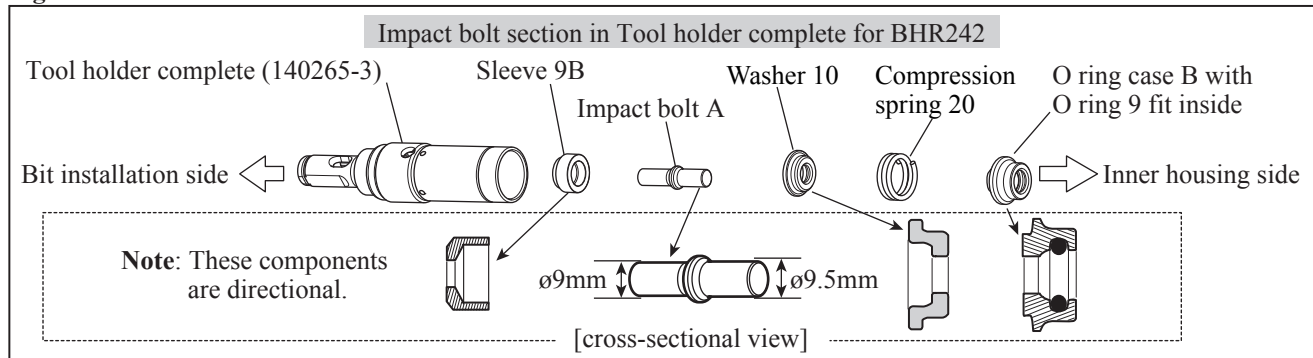
**[3] DISASSEMBLY/ASSEMBLY**

**[3]-6. Impact bolt in Torque limiter section (cont.)**

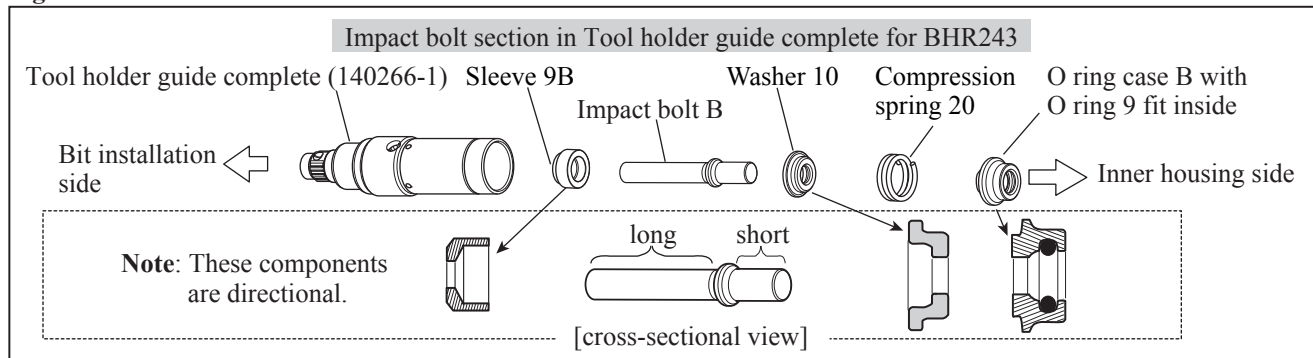
**ASSEMBLING**

(1) Assemble Impact bolt section to Tool holder (guide) complete as drawn in **Fig. 44A/ 44B**.

**Fig. 44A**



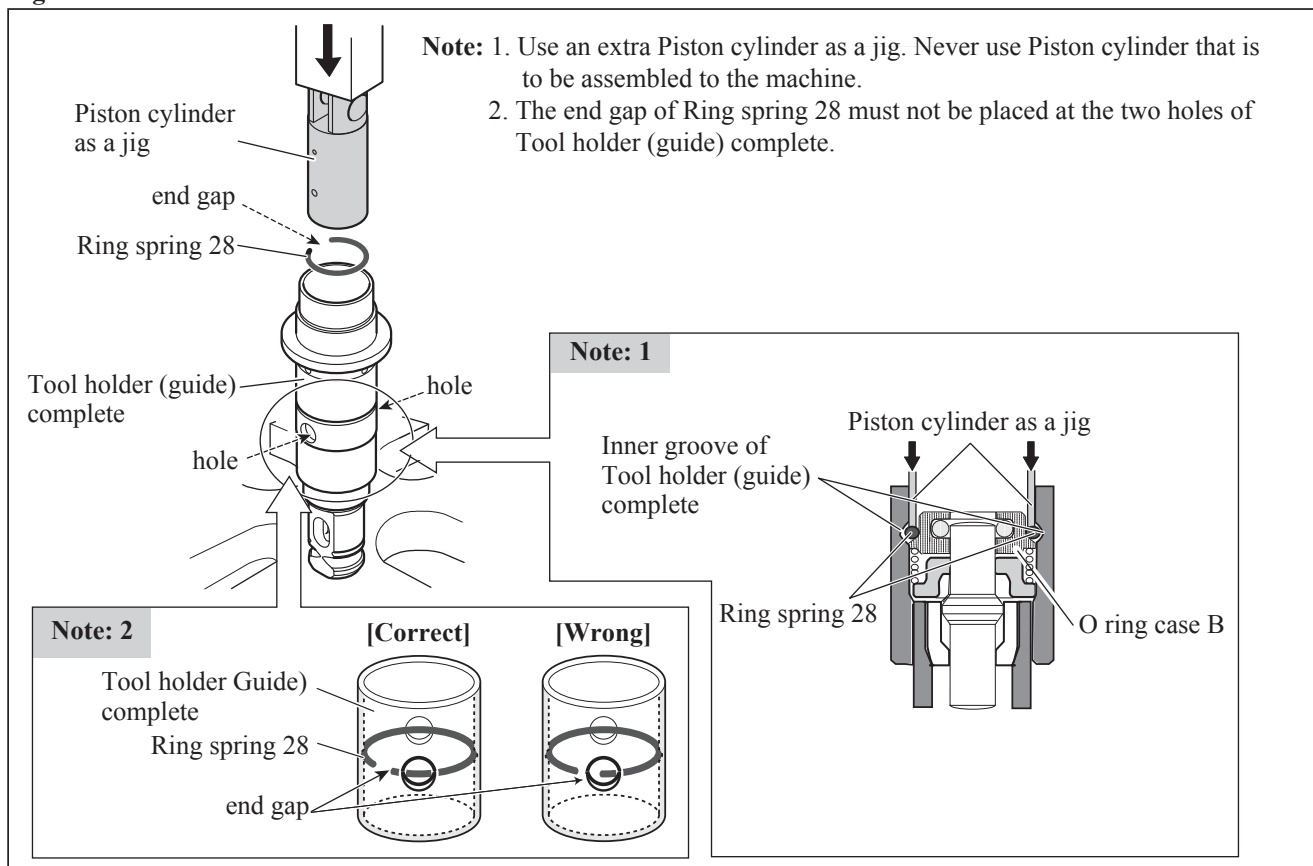
**Fig. 44B**



(2) Push Ring spring 28 into the inner groove of Tool holder (guide) complete as drawn in **Fig. 45**.

**Note:** Do not reuse the removed Ring spring 28 if it is deformed or damaged.

**Fig. 45**



► **Repair**

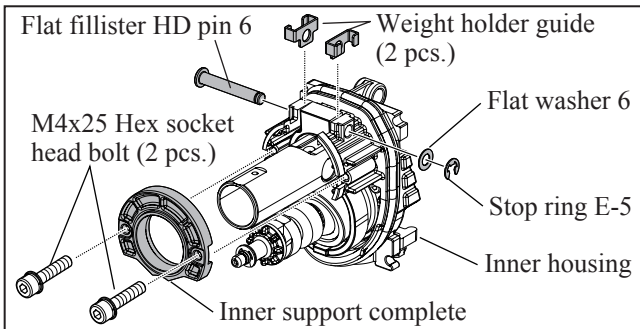
**[3] DISASSEMBLY/ASSEMBLY**

**[3]-7. Swash bearing section, Piston cylinder section**

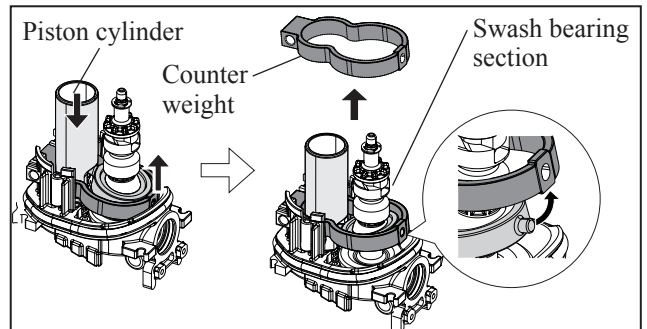
**DISASSEMBLING**

- (1) Disassemble Motor housing section, Gear housing section and Inner housing section.
- (2) Remove Flat fillister HD pin 6, two Weight holder guides, Flat washer 6, Stop ring E-5, Inner support complete and two M4x25 Hex socket head bolts from Inner housing. **(Fig. 47)**
- (3) While pushing Piston cylinder, remove Counter weight from Swash bearing section as drawn in **Fig. 48**.
- (4) Remove two M4x12 Hex socket head bolts with 1R170 or 1R228. **(Fig. 49)**
  - Then pull Swash bearing section and Piston cylinder section out of Inner housing. **(Fig. 49)**
  - Swash bearing section can be removed from Piston cylinder section with Inner housing attached as drawn in **Fig. 50**.
- (5) Remove Ball bearing 606ZZ from Gear housing complete using the removed Swash bearing section. **(Fig. 51)**

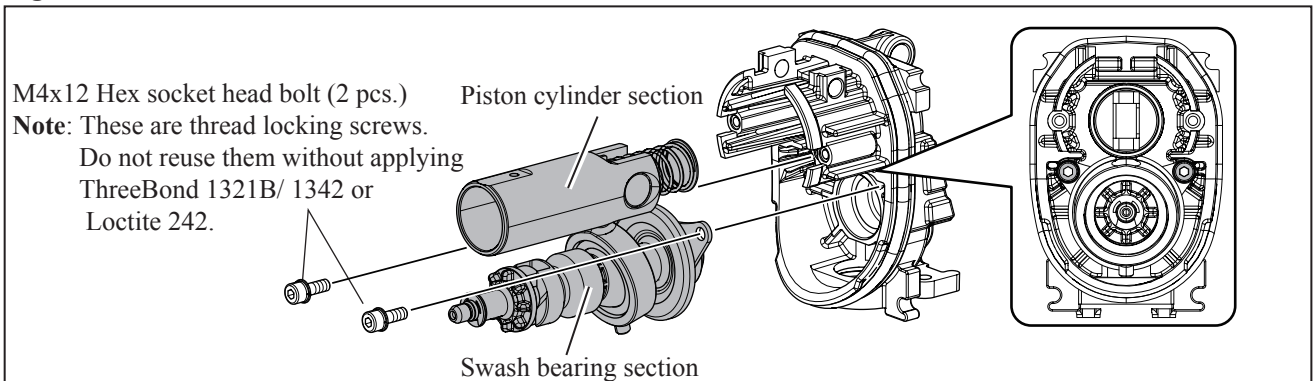
**Fig. 47**



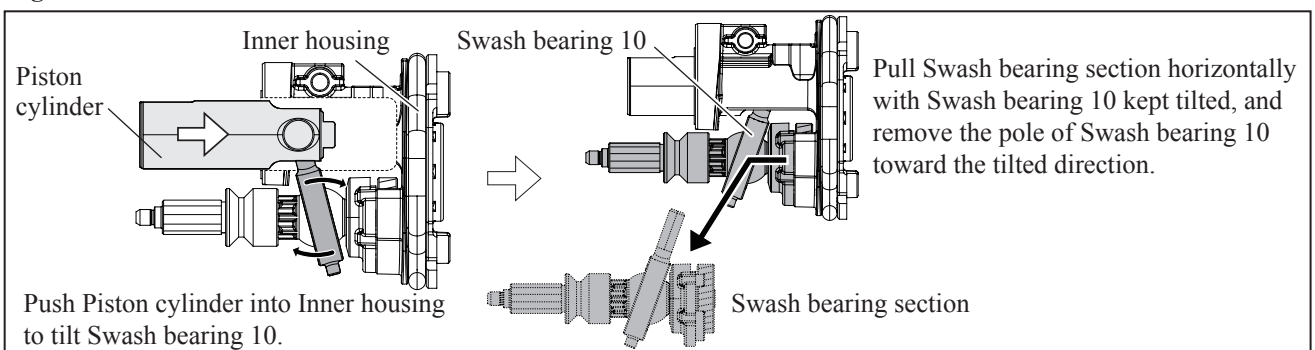
**Fig. 48**



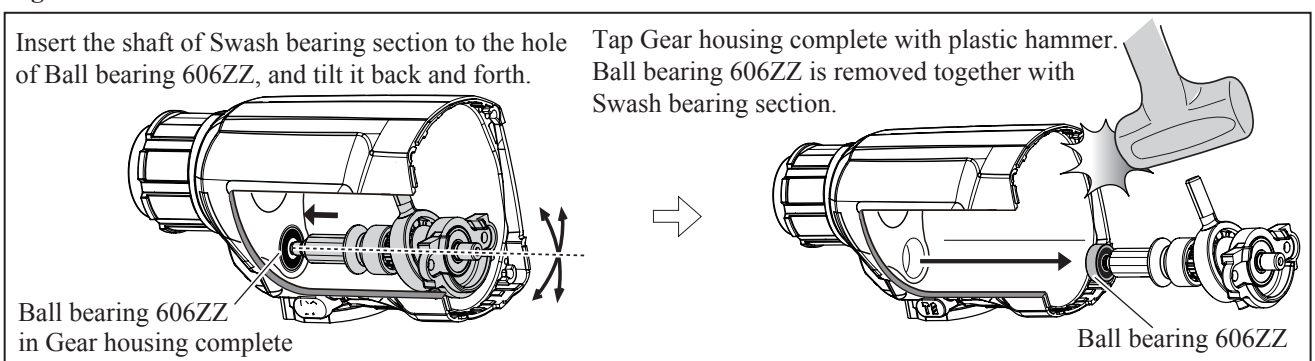
**Fig. 49**



**Fig. 50**



**Fig. 51**





► **Repair**

**[3] DISASSEMBLY/ASSEMBLY**

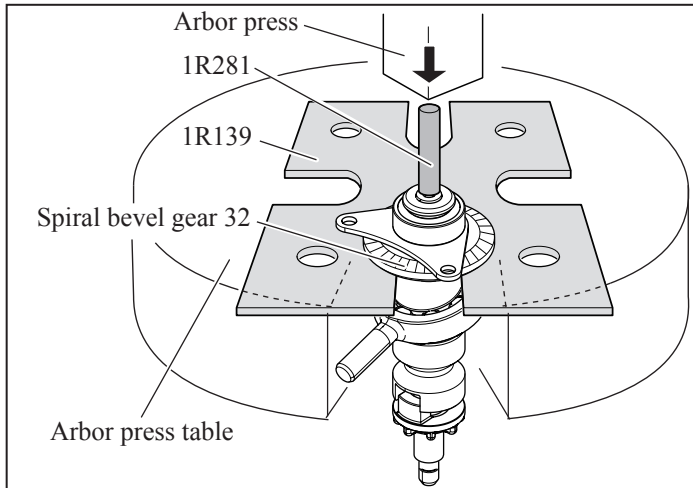
**[3]-7. Swash bearing section (cont.)**

**DISASSEMBLING**

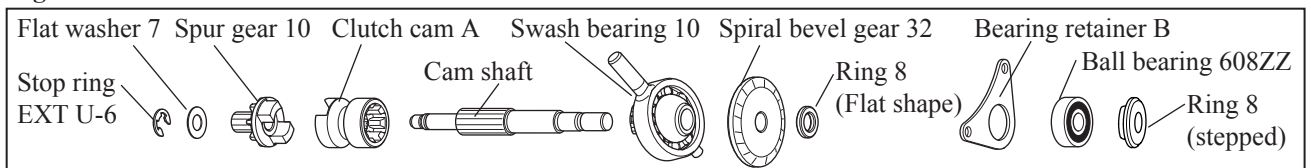
- (6) Remove Stop ring EXT U-6 from Can shaft, then separate Flat washer 7, Spur gear 10 and Clutch cam A from Can shaft.
- (7) Receive Spiral bevel gear 32 on 1R139 put on U-groove of Arbor press table and press out Cam shaft with 1R281 ( $\phi 7$ mm round bar) as drawn in **Fig. 52**.

The swash bearing section can be removed as drawn in **Fig. 53**.

**Fig. 52**



**Fig. 53**



**ASSEMBLING**

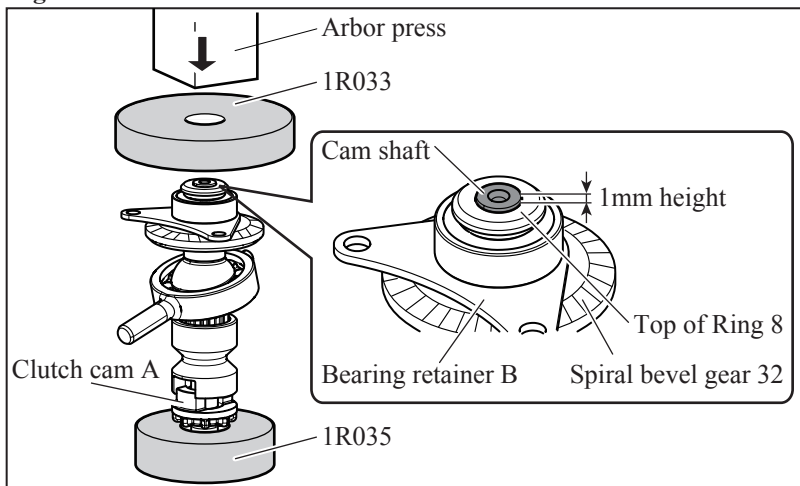
Assemble the Swash bearing section carefully to the directions of each part and the order shown in **Fig. 53**.

- (1) Pass Cam shaft through Clutch cam A, and then receive Clutch cam A on 1R035.
- (2) Pass Cam shaft through Swash bearing 10 and press-fit Spiral bevel gear 32 to Cam shaft until Spiral bevel gear stops.
- (3) Pass Cam shaft through Ring 8 and Bearing retainer B, and then press-fit Ball bearing 608ZZ and Ring 8 to Cam shaft with 1R033 carefully. Do not pinch Bearing retainer B by Ball bearing 608ZZ and Spiral bevel gear 32.

**Note:** When 1mm height of Cam shaft is projected out over Ring 8, the assembling work is successful. (**Fig. 54**) Check the height at this time.

- (4) Set Spur gear 10 and Flat washer 7 in place on Cam shaft, and secure them with Stop ring EXT U-6.

**Fig. 54**



► **Repair**

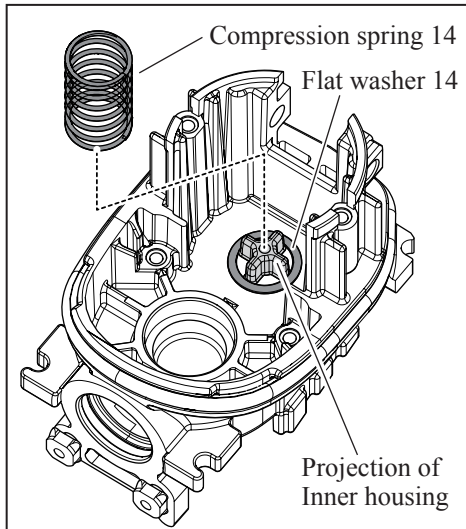
**[3] DISASSEMBLY/ASSEMBLY**

**[3]-7. Swash bearing section, Piston cylinder section (cont.)**

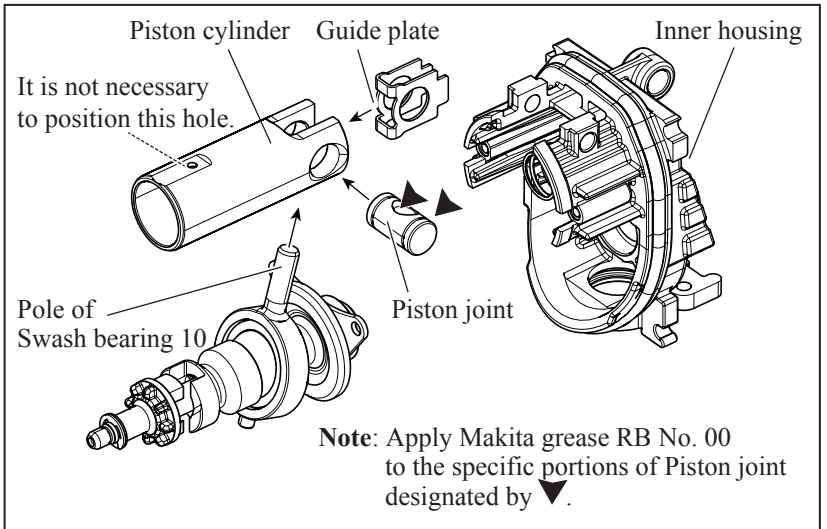
**ASSEMBLING**

- (5) Set Compression spring 14 and Flat washer 14 to the projection of Inner housing as drawn in **Fig. 55**.  
Insert Guide plate and Piston joint into Piston cylinder, and then pass the pole of Swash bearing 10 through Piston joint. (**Fig. 56**)
- (6) Assemble Inner support complete to Inner housing with two M4x25 Hex socket head bolts. (Refer to **Fig. 47**)
- (7) Make sure that the gear teeth of Clutch cam A engage those of Swash bearing 10. (**Fig. 57**)
- (8) Assemble Compression spring 4 and Lock plate to Gear housing. (**Fig. 58**)  
**Note:** Apply Makita grease RB No. 00 to the end of Compression spring 4 on Lock plate mating side in order to do the next step smoothly.
- (9) While holding Lock plate by a finger so as not to drop from the guides of Gear housing, assemble Gear housing to Inner housing. (**Figs. 58 and 59**)

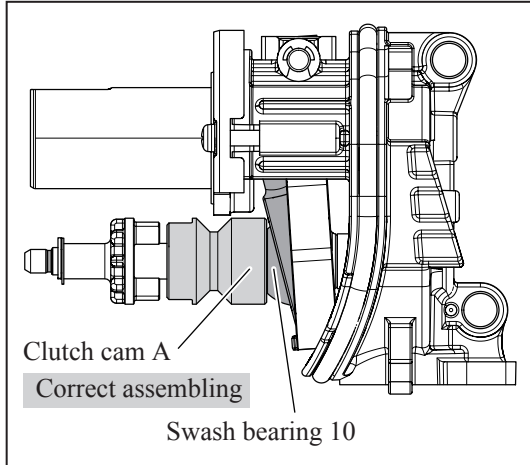
**Fig. 55**



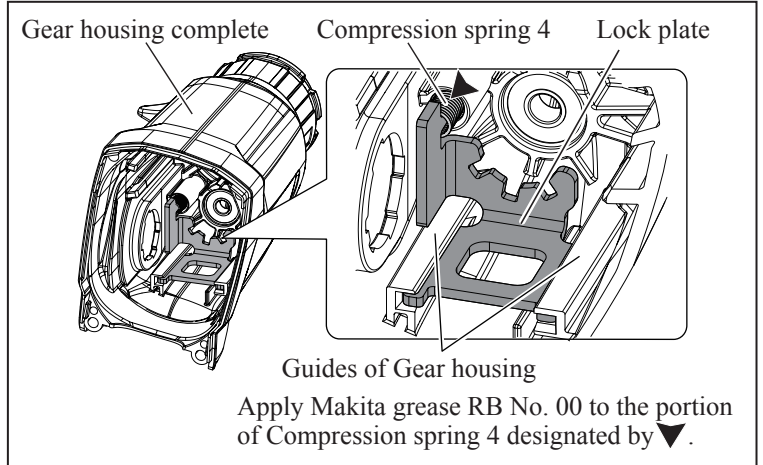
**Fig. 56**



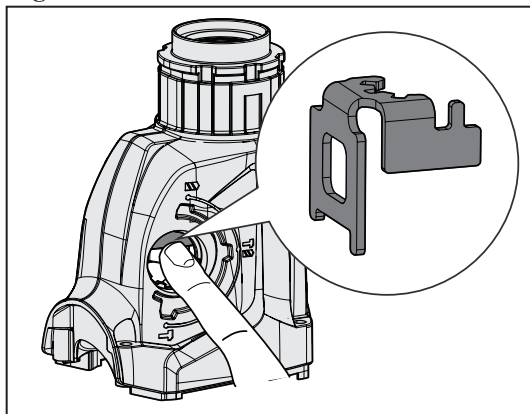
**Fig. 57**



**Fig. 58**



**Fig. 59**



► **Repair**

**[3] DISASSEMBLY/ASSEMBLY**

**[3]-8. Oil seal 25, Cup sleeve, Ball bearing 6806LLU**

**DISASSEMBLING**

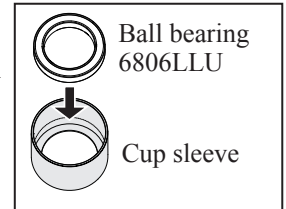
- (1) Assemble Inner housing complete to Gear housing complete.
- (2) Put Inner housing complete on U-groove table portion of arbor press, then press Oil seal 25, Cup sleeve and Ball bearing 6806LLU out of Gear housing complete using 1R252.

**ASSEMBLING**

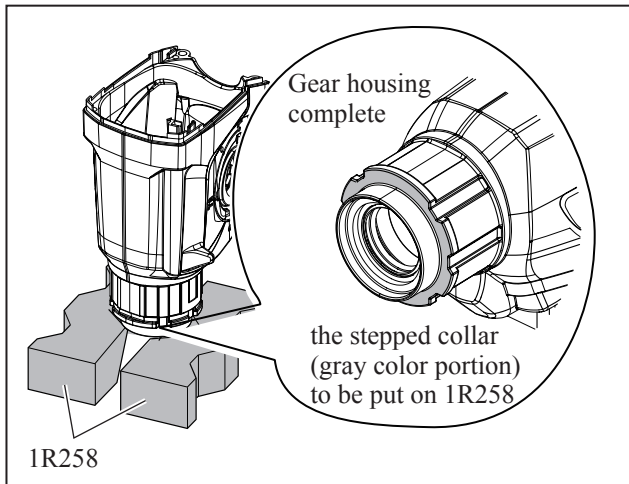
- (1) Press-fit Ball bearing 6806LLU into Cup sleeve. (**Fig. 60**)
- (2) While receiving the stepped collar of Gear housing complete on 1R258 as drawn in **Fig. 61**, press-fit Oil seal 25 with 1R232 until it stops. (**Fig. 62**)  
Oil seal 25 is not yet inserted completely because the outer diameter of 1R232 is larger than that of Oil seal setting hole.
- (3) Press-fit Oil seal 25 to the original position with 1R164 until it stops. (**Fig. 63**)
- (4) Press-fit Cup sleeve with Ball bearing 6806LLU into the place using 1R273. (**Fig. 64**)

**Note:** Too much pressure will deform Oil seal 25 and Cup sleeve. Press-fit them **with gentle pressure**.

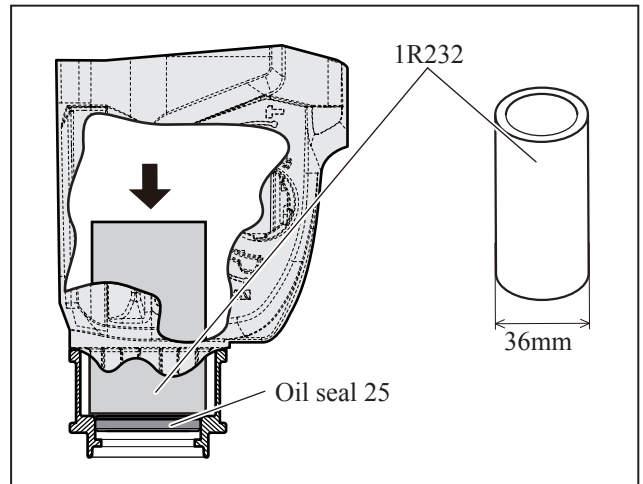
**Fig. 60**



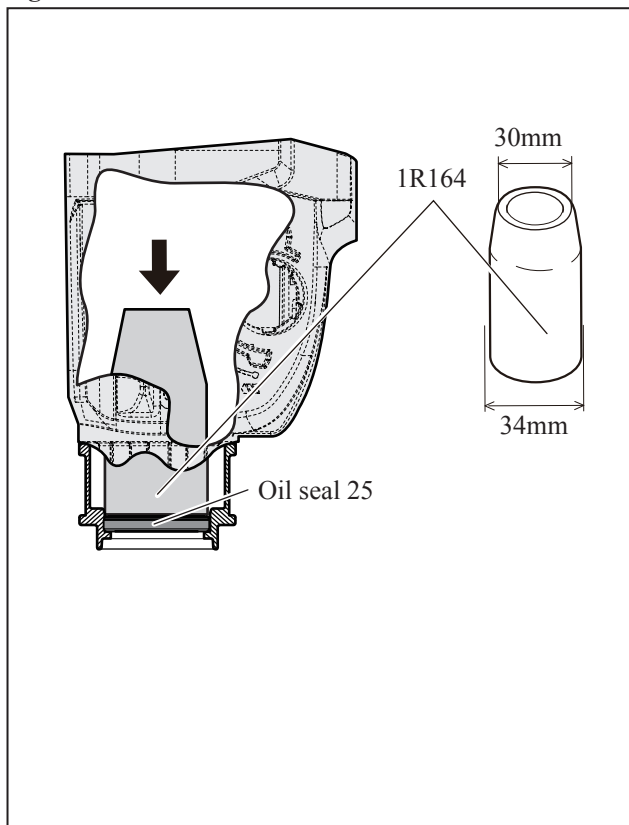
**Fig. 61**



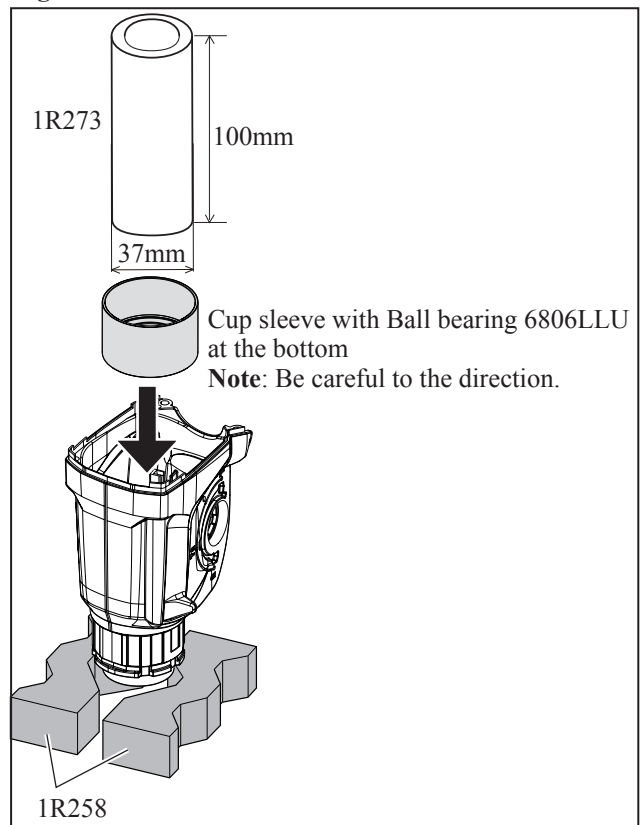
**Fig. 62**



**Fig. 63**



**Fig. 64**



## ► Repair

### [3] DISASSEMBLY/ASSEMBLY

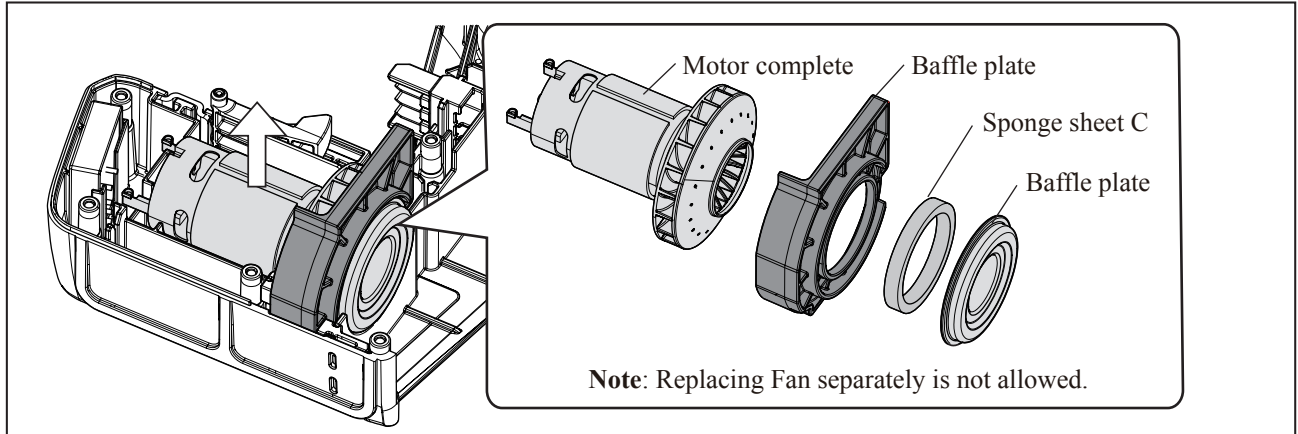
#### [3]-9. Motor of Dust extraction system DX01, DX02

**Note: Special repairing tool and Lubricant are not required.**

#### DISASSEMBLING

- (1) Separate Housing R and eight 4x18 Tapping screws from Housing L.
- (2) Remove Baffle plate, Filter plate, Sponge sheet C and Motor complete as an assembled part. (**Fig. 65**)

**Fig. 65**

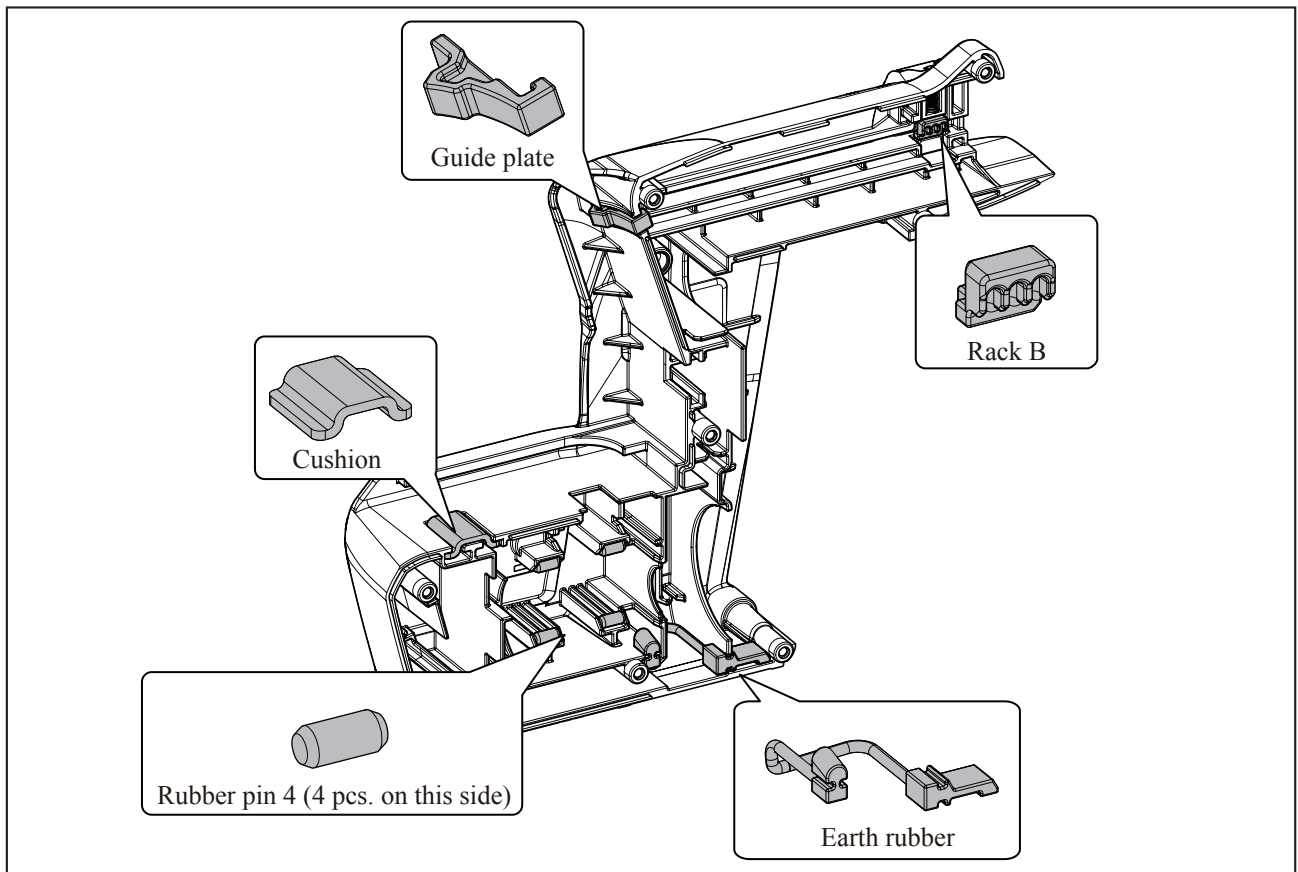


#### ASSEMBLING

Assemble the components by reversing the disassembly procedure.

Guide plate, Cushion and four Rubber pins 4 are on not only Housing R but also Housing L, and therefore, be careful not to drop their parts.

**Fig. 66**



► **Repair**

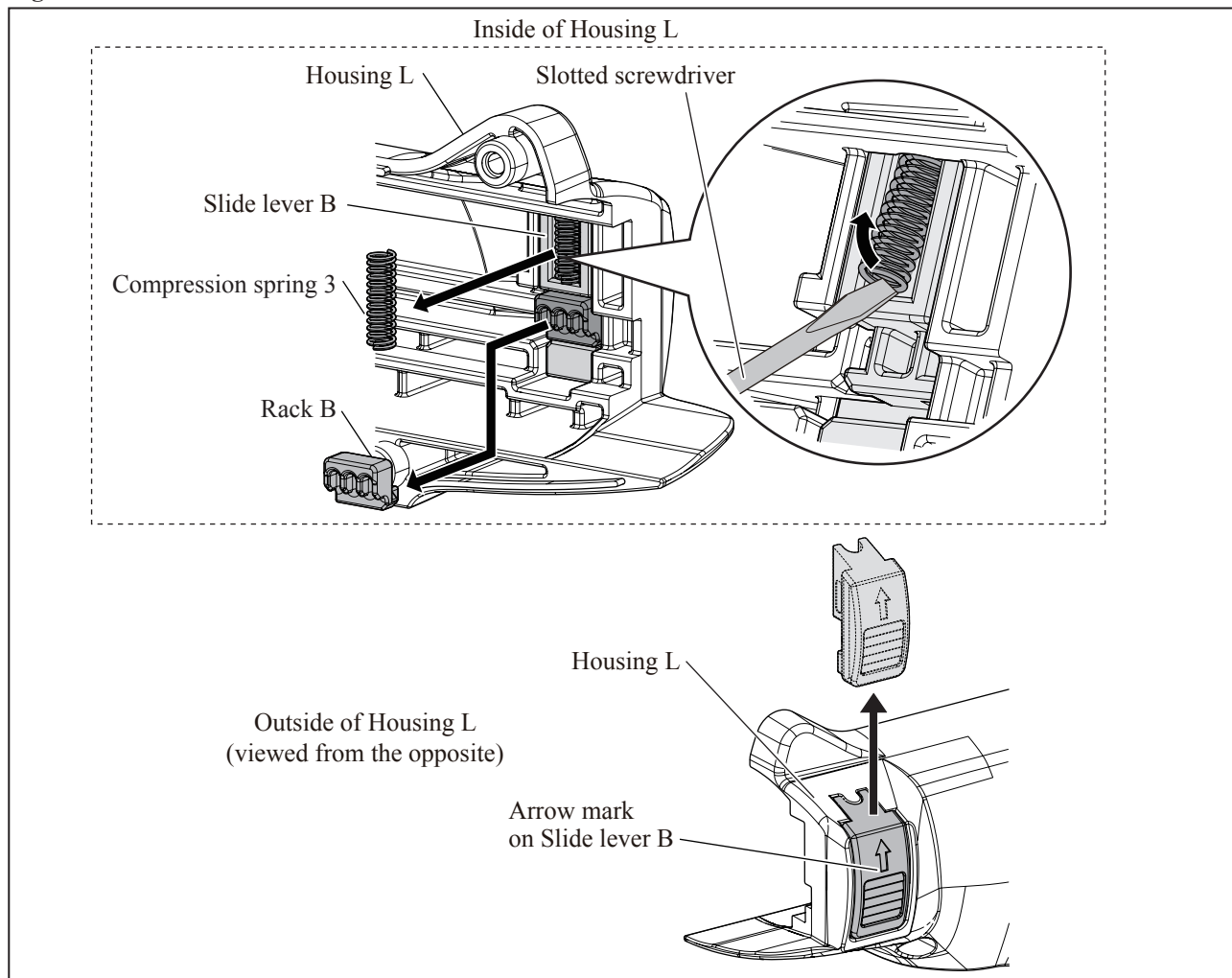
**[3] DISASSEMBLY/ASSEMBLY**

**[3]-10. Slide levers of Dust extraction system DX01, DX02**

**DISASSEMBLING**

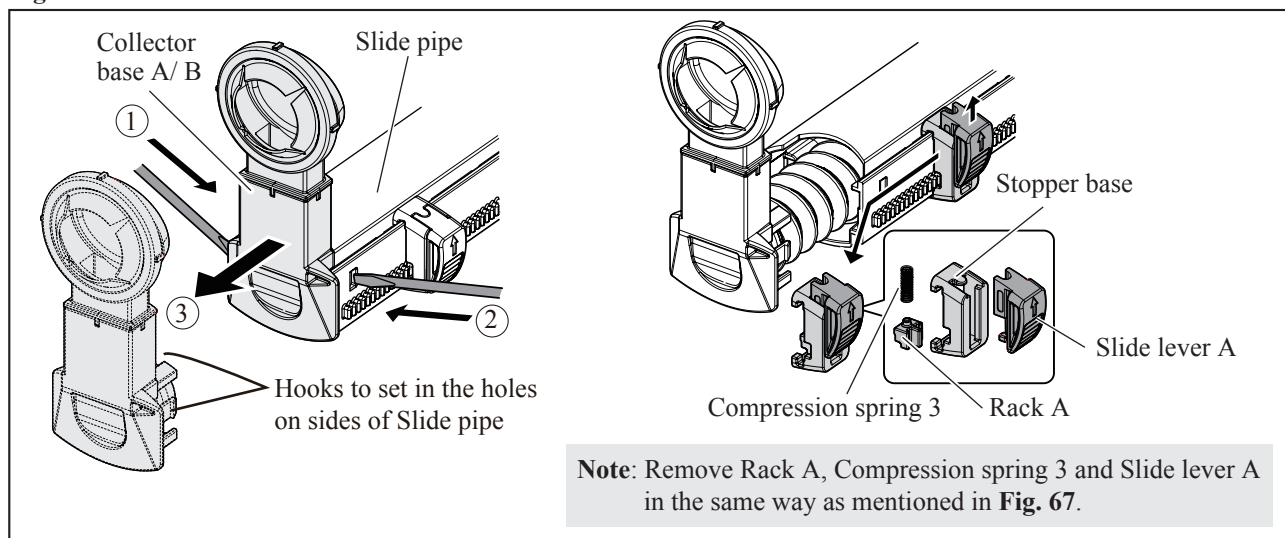
- Slide lever B on Housing L  
Remove Rack B and Compression spring 3 in Housing L as drawn in **Fig. 67**, and then move Slide lever B toward the upper direction like the arrow mark. (**Fig. 67**)

**Fig. 67**



- Slide lever A on Slide pipe  
Remove Collector base A (DX01)/ B (DX02) from Slide pipe by releasing the hooks with a thin-slotted screwdriver, and then separate Rack A, Compression spring 3, Stopper base and Slide lever A. (**Fig. 68**)

**Fig. 68**



## ► Repair

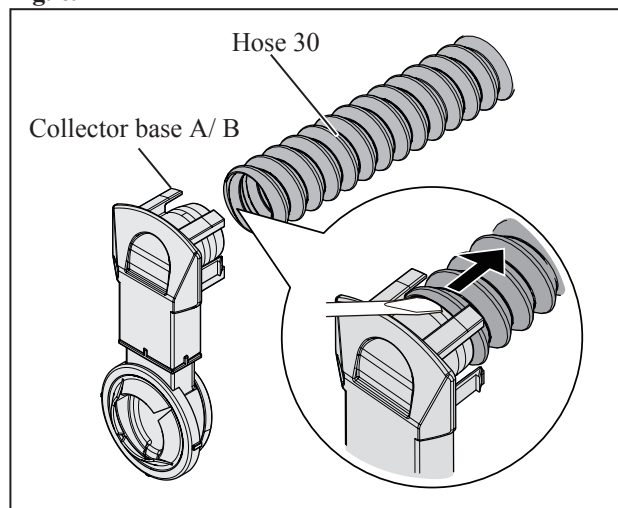
### [3] DISASSEMBLY/ASSEMBLY

#### [3]-11. Tips on repair of Dust extraction system DX01, DX02

##### DISASSEMBLING

- Hose 30 is not glued on the other parts, and therefore it is possible to remove Hose 30 from Collector base A (DX01)/ B (DX02) and Inner pipe. (**Fig. 69**)  
When it is difficult to remove because of the tight contact, peel it with a thin-slotted screwdriver. (**Fig. 69**)

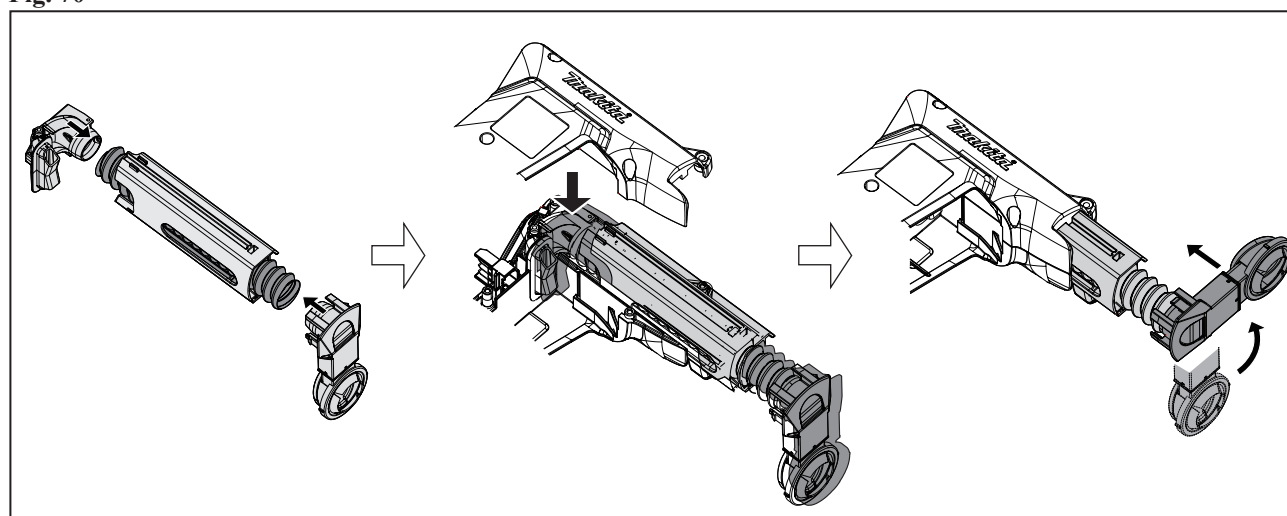
**Fig. 69**



##### ASSEMBLING

- Hose 30 is not glued on the other parts, and therefore it is possible to remove Hose 30 from Collector base A (DX01)/ B (DX02) and Inner pipe. (**Fig. 69**)  
When it is difficult to remove because of the tight contact, peel it with a thin-slotted screwdriver. (**Fig. 69**)
- When reassembling Collector base A/B and Inner pipe, keep a right angle between them.  
In assembly of housing L to R and shrinkage of Hose 30, while turning the hose 30 counterclockwise, snap the hooks of Collector base A/ B into the holes of Slide pipe as drawn in **Fig. 70**. (Reverse the step shown in **Fig. 68**.)
- While turning Hose 30 clockwise, adjust your desired positions of Hose, Collector base A/ B and Inner pipe each other.  
The inner diameter of the spring of Hose is expanded, and consequently this way allows loose contact of Hose during revolving.

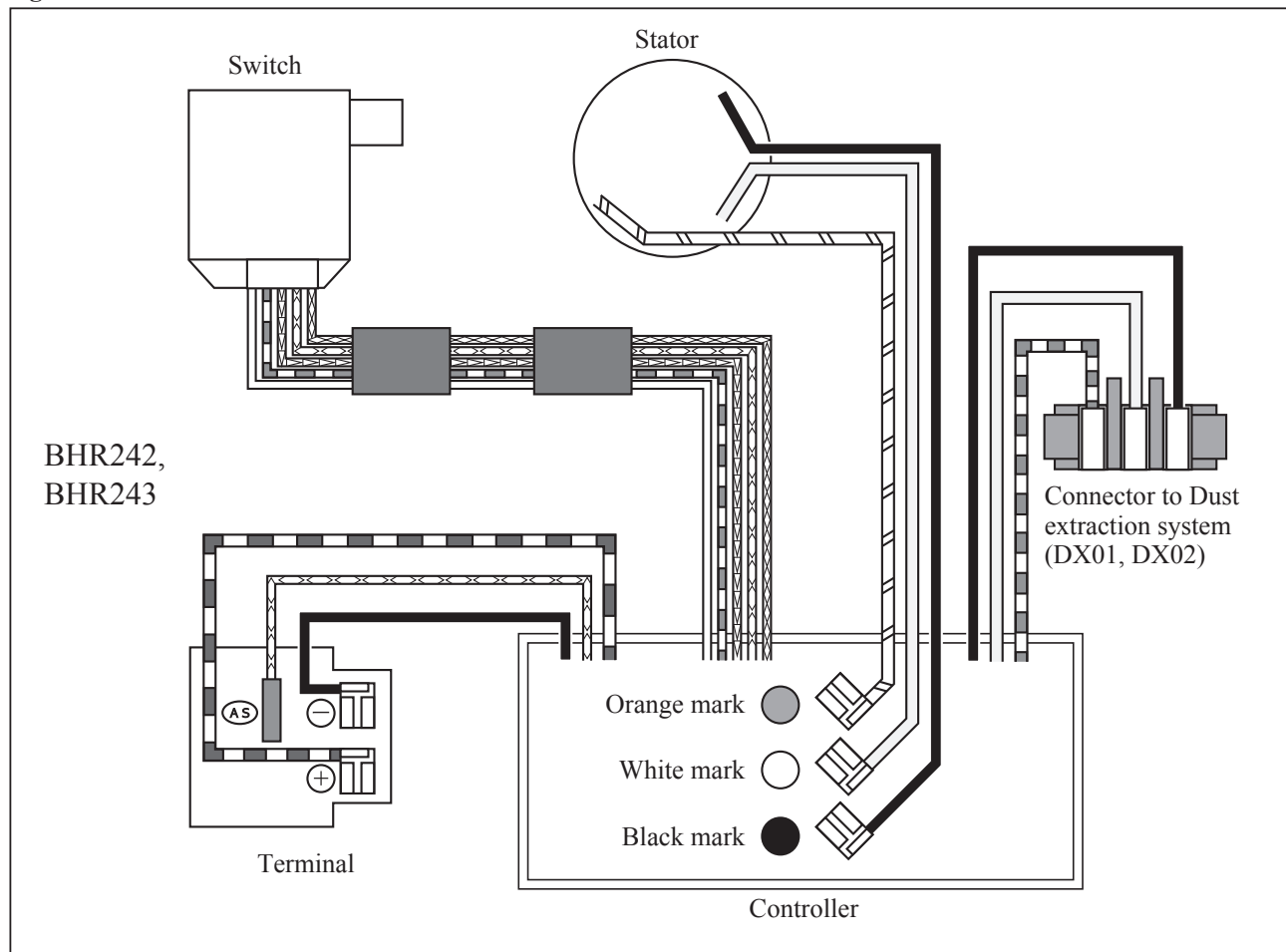
**Fig. 70**



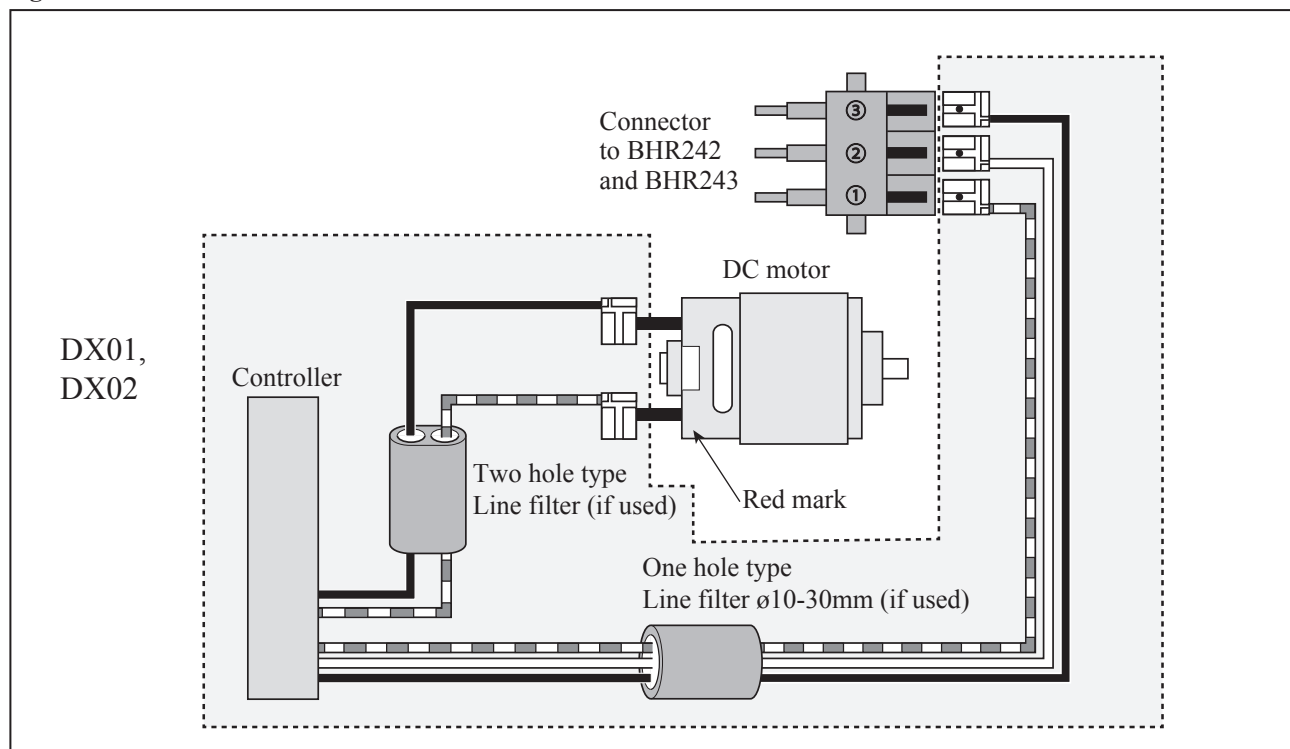
► **Circuit diagram**

Color index of lead wire's sheath			
Black		Orange	
White		Blue	
Red		Yellow	
		Brown	

**Fig. D-1**

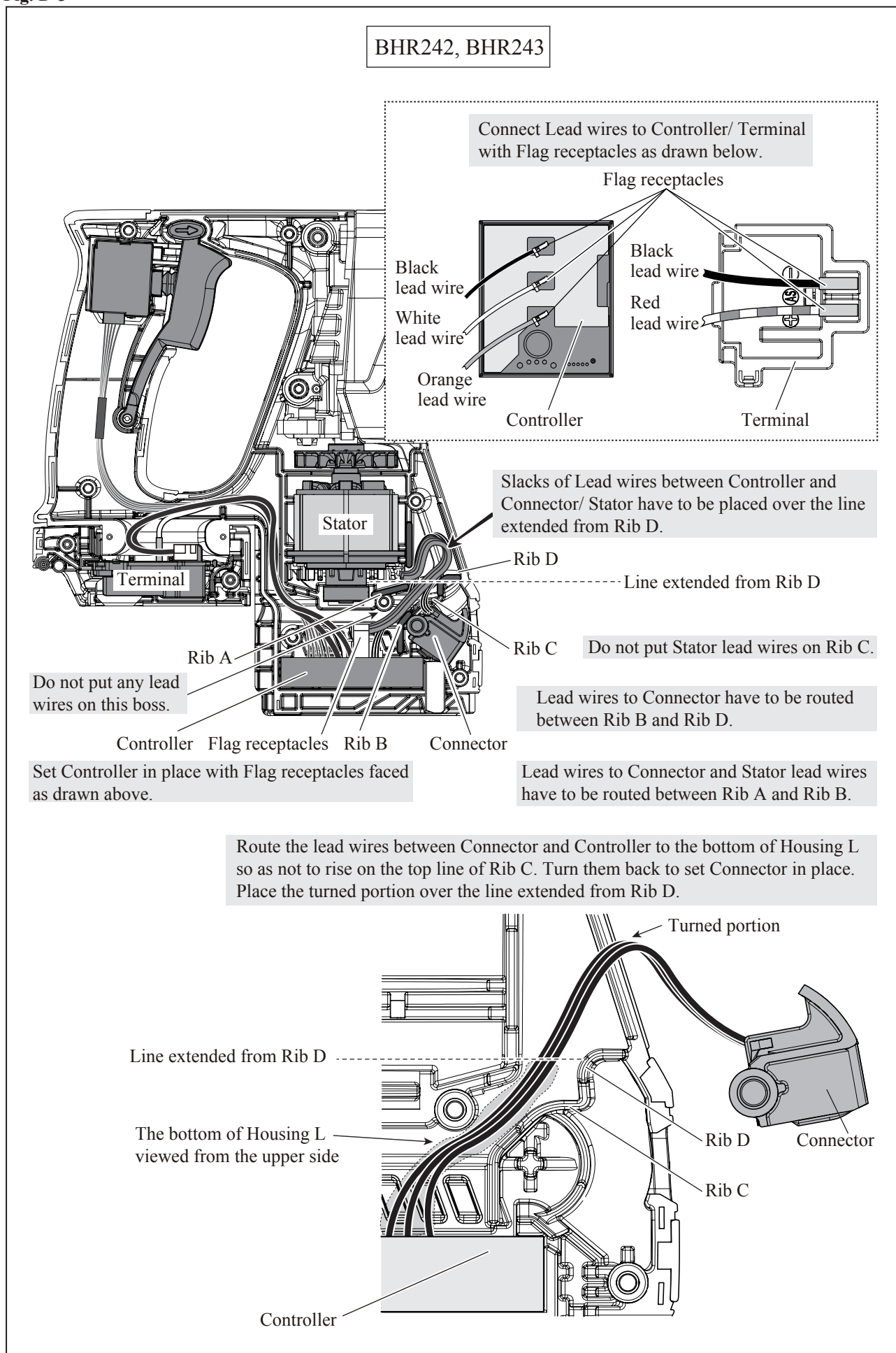


**Fig. D-2**



► **Wiring diagram**

Fig. D-3





# ▶ Wiring diagram (cont.)

Fig. D-4

